

MODEL 4650

Service Manual



IMPORTANT: Fill in pertinent information on page 2 for future reference.

MODEL 4650

Job Specification Sheet

- JOB NO. _____
- MODEL NO. _____
- WATER TEST _____
- CAPACITY PER UNIT _____ MAX. _____ PER REGENERATION
- MINERAL TANK SIZE DIA. _____ HEIGHT _____
- BRINE TANK SIZE & SALT SETTING PER REGENERATION:

CONTROL VALVE SPECIFICATIONS

Type of Timer

A) "L" B) 7 Day C) 12 Day

Day/Time of Regeneration _____

Drain Line Flow Control _____ gpm

Brine Refill Rate _____ gpm

Injector Size _____

MODEL 4650

Installation and Start-up Procedure

The water softener should be installed with the inlet, outlet and drain connections made in accordance with manufacturer's recommendations and to meet applicable plumbing codes.

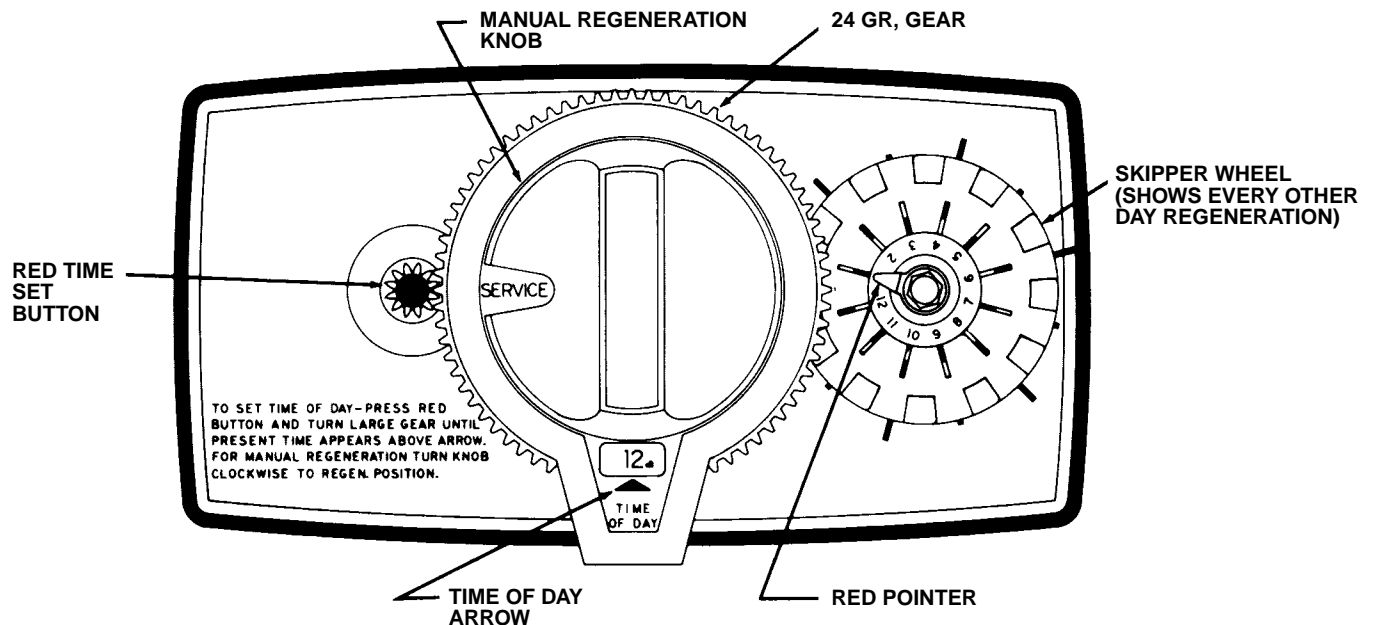

1. Manually index the softener control into the service position and let water flow into the resin tank. When the water flow stops, open a softened water tap until all air is released from the lines, then close the tap.
Note: the various regeneration positions may be dialed manually by turning the knob on the front of the control until the indicator shows that the softener is in the desired position.
2. Manually index the control to the back-wash position and allow water to flow at the drain for 3 or 4 minutes.
3. Remove back cover plate.
4. Make sure that the salt dosage is set as recommended by the manufacturer. Manually index the control to the brine fill position and allow the brine tank to fill to the top of the air check.
5. Manually index the control to the brine draw position and allow the control to draw water from the brine tank until it stops.
6. Plug in the electrical cord and look in the sight hole in the back of the motor to see that it is running. Set the days that regeneration is to occur by sliding tabs on skipper wheel outward to expose trip fingers. Each tab is one day. Finger at red pointer is tonight. Moving clockwise from red pointer, extend or retract fingers to obtain the desired regeneration schedule.
7. Manually advance the control to the beginning of the brine fill position; and allow the control to return to the service position automatically.
8. Fill the brine tank with salt.
9. Replace back cover on the control.
10. Make sure that any by-pass valving is left in the normal service position.

MODEL 4650

Control Valve Drive Assembly

(See opposite page for parts list)

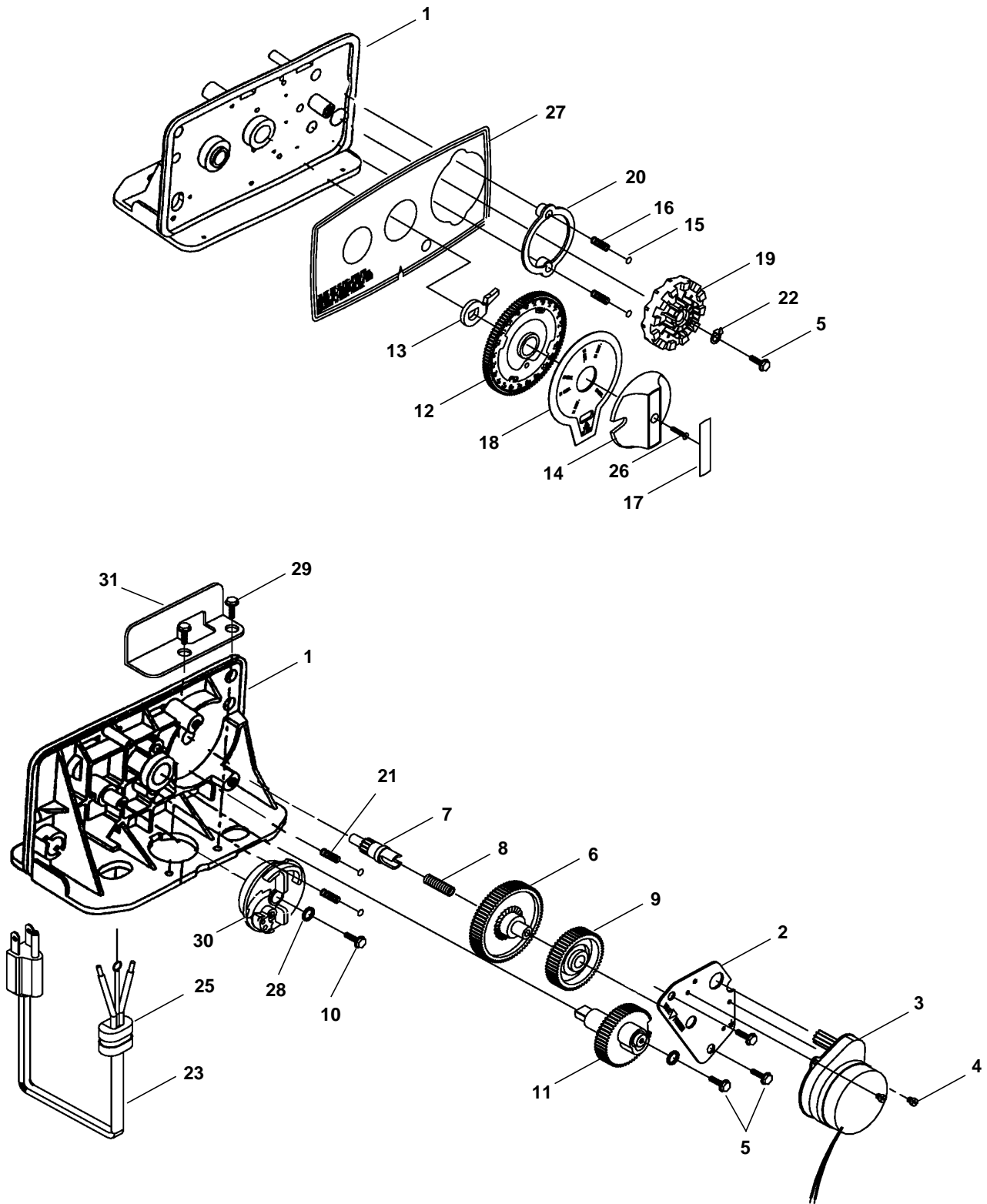

MODEL 4650

Control Valve Drive Assembly

Parts List

Item No.	Quantity	Part No.	Description
1	1	15494-01	"L" Housing - w/Pin
2	1	13175	Motor Mounting Plate
3	1	18743	Motor - 120V., 60 Hz.
	1	19659	Motor - 24V., 60 Hz.
4	3	11384	Screw - Motor Mtg. & Ground Wire
5	3	13296	Screw - Component Mounting
6	1	13017	Idler Gear
7	1	13018	Idler Pinion
8	1	13312	Spring - Idler
9	1	13164	Drive Gear
10	1	40214	Screw - Brine Cam
11	1	13170	Main Gear & Shaft
12	1	19205-01	24 Hour Gear Assembly, Silver
13	1	13011	Cycle Actuator Gear
14	1	14177	Knob - Manual Regeneration
15	4	13300	Ball - 1/4" Dia.
16	2	13311	Spring - Detent - Skipper Wheel
17	1	14207	Knob Label - Silver
18	1	14176	Valve Position Dial - Standard
19	1	14381	Skipper Wheel Assembly - 12 Day
	1	14860	Skipper Wheel Assembly - 7 Day
20	1	13864	Skipper Wheel Ring
21	2	14457	Spring - Detent - Main Gear
22	1	13014	Regeneration Pointer
23	1	11842	Electrical Cord - Standard
24	2	12681	Wire Connector (Not Shown)
25	1	13547	Strain Relief
26	1	15151	Screw - Knob
27	1	14331	Front Label - Silver on Black
28	1	12037	Washer
29	2	12473	Screw-Drive Mounting
30	1	60514	Brine Cam Assembly, 3-18
	1	60514-01	Brine Cam Assembly, 6-36
	1	60514-02	Brine Cam Assembly, Minutes
*31	1	40327	Support Bracket

* Hot Water Only

MODEL 4650

Control Drive Assembly for Clock

(See opposite page for parts list)

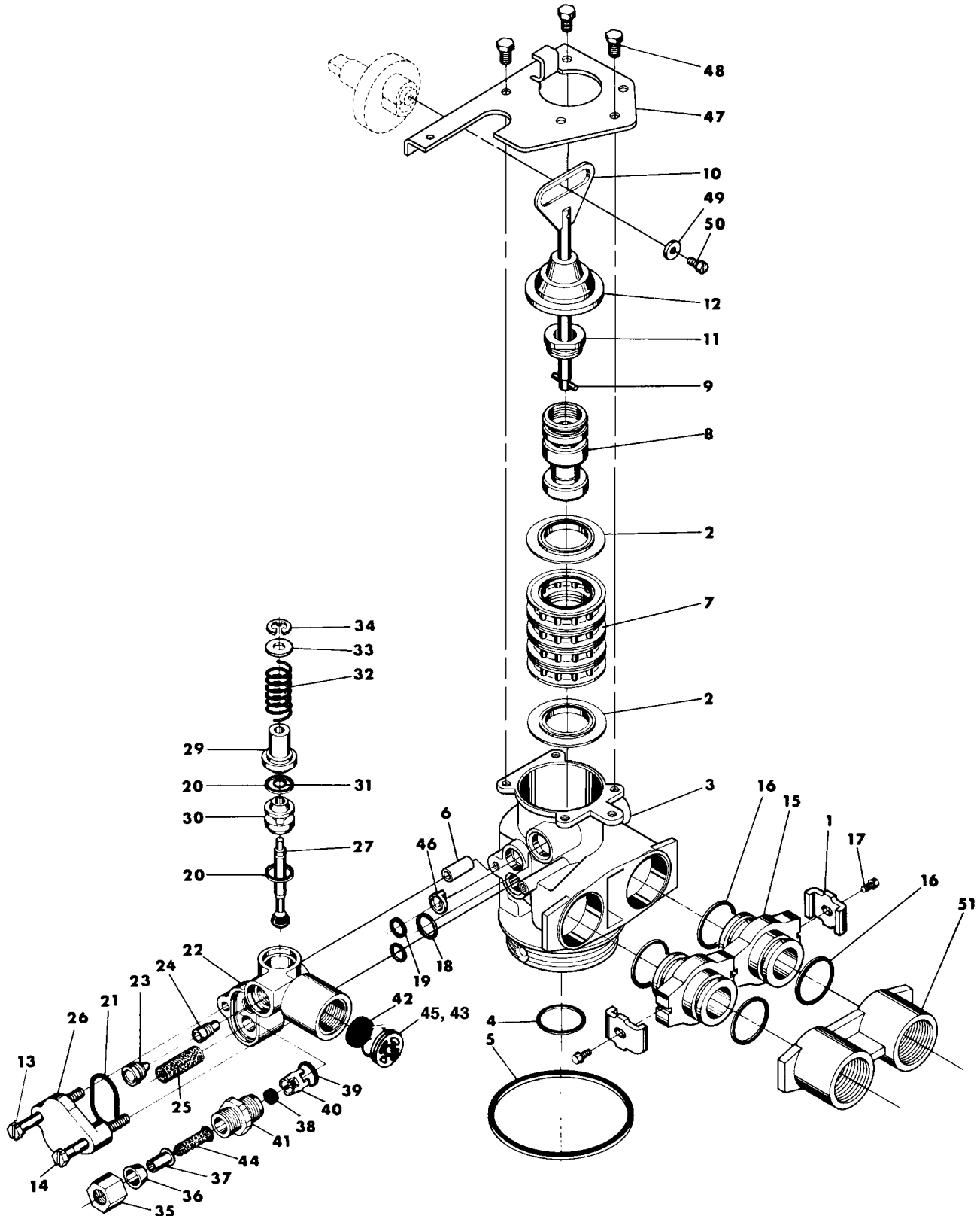

Item No.	Quantity	Part No.	Description
1.	2	13255	Adapter Clip
2.	5	13242	Seal
3.	1	40319	Valve Body
4.	1	13304	O-Ring - Distributor Tube - 1"
5.	1	10381-01	O-Ring - Top of Tank - Hot Water
	1	10381	O-Ring - Top of Tank - Cold Water
6.	1	13361	Stand-Off
7.	4	14241-01	Spacer - Hot Water
	4	14241	Spacer - Cold Water
8.	1	13247	Piston - Standard
9.	1	10696	Piston Pin
10.	1	13001	Piston Rod Assembly
11.	1	12953	Piston Retainer
12.	1	61411	End Plug Assembly, Brass - Hot Water
	1	13446	End Plug Assembly, Std., White - Cold Water
13.	1	13387	Screw - Injector Mounting
14.	1	13315	Screw - Injector Mounting
15.	2	19228	Adapter Coupling
16.	4	13305	O-Ring - Adapter Coupling
17.	4-4	13314	Screw - Adapter Coupling
18.	1	12638-01	O-Ring - Drain - Hot Water
	1	12638	O-Ring - Drain - Cold Water
19.	2	13301-01	O-Ring - Injector - Hot Water
	2	13301	O-Ring - Injector - Cold Water
20.	2	13302-01	O-Ring - Brine Spacer - Hot Water
	2	13302	O-Ring - Brine Spacer - Cold Water
21.	1	13303-01	O-Ring - Injector Cover - Hot Water
	1	13303	O-Ring - Injector Cover - Cold Water
22.	1	13163	Injector Body
23.	1	10225-xx	Injector Nozzle - Hot Water
	1	10913-xx	Injector Nozzle - Cold Water
24.	1	10226-xx	Injector Throat - Specify Size - Hot Water
	1	10914-xx	Injector Throat - Specify Size - Cold Water
25.	1	10227	Injector Screen
26.	1	13166	Injector Cover
27.	1	13172-03	Brine Valve Stem Assembly - Hot Water
	1	13172-02	Brine Valve Stem Assembly - Cold Water
29.	1	13165	Brine Valve Cap
30.	1	13167	Brine Valve Spacer
31.	1	12550-01	Quad Ring - Hot Water
	1	12550	Quad Ring - Cold Water
32.	1	11973	Spring - Brine Valve
33.	1	16098	Washer - Brine Valve
34.	1	11981-01	Retaining Ring
35.	1	10329	B.L.F.C. Fitting Nut
36.	1	10330	B.L.F.C. Ferrule
37.	1	10332	B.L.F.C. Tube Insert
38.	1		B.L.F.C. Button - Specify Size
39.	1	12977-01	O-Ring - B.L.F.C. - Hot Water
	1	12977	O-Ring - B.L.F.C. - Cold Water
40.	1	13245	B.L.F.C. Button Retainer
41.	1	13244	B.L.F.C. Fitting
42.	1		D.L.F.C. Button - Specify Size
43.	1	13173	D.L.F.C. Button Retainer
44.	1	12767	Screen - Brine Valve
45.	1	15348	O-Ring - D.L.F.C. (not shown)
46.	1	13497	Air Disperser
47.	1	13546	End Plug Retainer
	1	40324	End Plug Retainer, Hot Water
48.	3	12112	Screw
49.	1	13363	Washer
50.	1	13296	Screw
51.	1	13398	Yoke, Brass, 1" NPT
	1	13708	Yoke, Brass, 3/4" NPT

MODEL 4650

By-Pass Valve Assembly

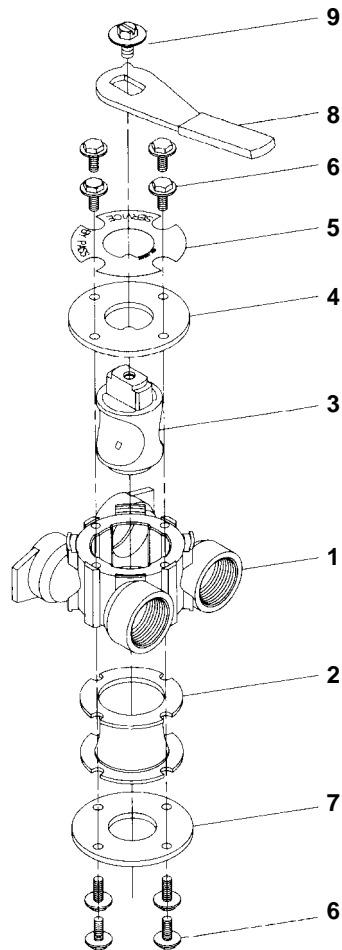

Item No.	Quantity	Part No.	Description
1	1	17290	By-Pass Valve Body, 3/4"
	1	17290NP	By-Pass Valve Body, 3/4" Nickel Plate
	1	13399	By-Pass Valve Body, 1"
	1	13399NP	By-Pass Valve Body, 1", Nickel Plate
2	1	11726	Seal, By-Pass
	1	14105	Seal, 3/4" By-Pass, Hot Water
3	1	11972	Plug, By-Pass
4	1	11978	Side Cover
5	1	13604-01	Label
6	8	15727	Screw
7	1	11986	Side Cover
8	1	11979	Lever, By-Pass
9	1	11989	Screw, Hex Head, 1/4-14

MODEL 4650

Service Assembly

60102-00 Piston Assy., Cold Water - Softener
60102-20 Piston Assy., Cold Water - Low Water
60102-031 Piston Assy. - Hot Water - Softener
60125 Seal Kit - Cold Water
60125-05 Seal Kit - Hot Water
60084-XXXX Injector - Cold Water
See Parts List,
Page 7 Injector - Hot Water
60032 Brine Valve - Cold Water
60032-001 Brine Valve - Hot Water
60514 Brine Cam, 3-18
60514-01 Brine Cam, 6-36
60514-02 Brine Cam, Minutes
60510 Coupling with Clip and Screws
60040 Bypass, Brass 3/4" NPT - Cold Water
60729-01 Bypass, Brass 3/4" NPT - Hot Water
60041 Bypass, Brass 1" NPT - Hot Water
60729-02 Bypass, Brass 1" NPT - Hot Water
14860 Skipper Wheel - 7 Day
14381 Skipper Wheel - 12 Day

Flow Control Washers

19153 0.6 gpm
19152 0.8 gpm
19151 1.0 gpm
12085 1.2 gpm
19150 1.3 gpm
12086 1.5 gpm
19149 1.7 gpm
12087 2.0 gpm
12088 2.4 gpm
12089 3.0 gpm
12090 3.5 gpm
12091 4.0 gpm
19147 4.5 gpm
12092 5.0 gpm
17814 6.0 gpm
12408 7.0 gpm

MODEL 4650

Water Conditioner Flow Diagrams

1 SERVICE POSITION

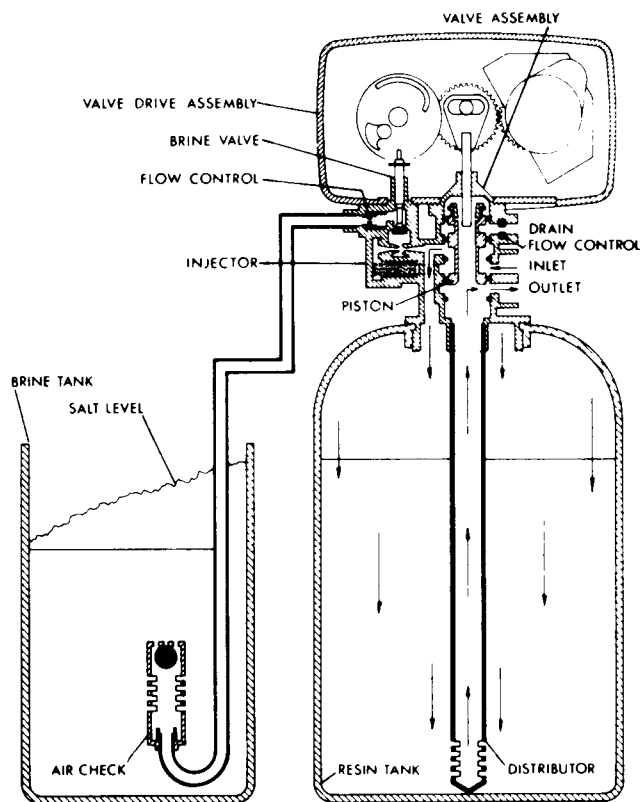

Hard water enters the unit at the valve inlet - flows around the lower piston groove - thru the passage to the top of tank - down thru the resin and enters the distributor as conditioned water. The conditioned water flows up thru the center tube to the valve outlet.

2 PRELIMINARY RINSE POSITION

5 Minutes

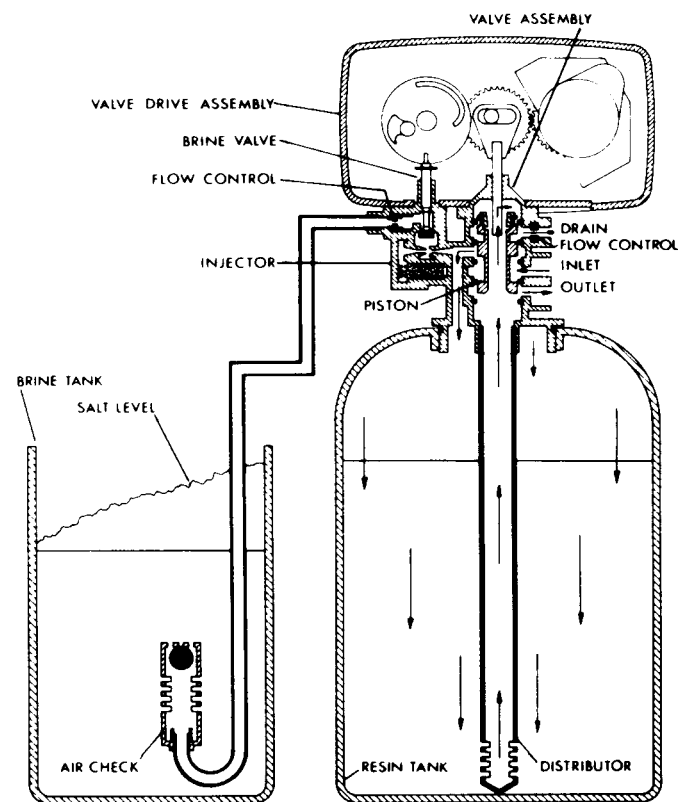

Hard water enters the unit at the valve inlet - flows around the lower piston groove - down thru the top of tank passage - downward thru the resin - up the distributor tube - thru the center hole in the piston - over the top edge of the piston and out the drain line.

MODEL 4650

Water Conditioner Flow Diagrams (Cont'd.)

3 BACKWASH POSITION

10 Minutes

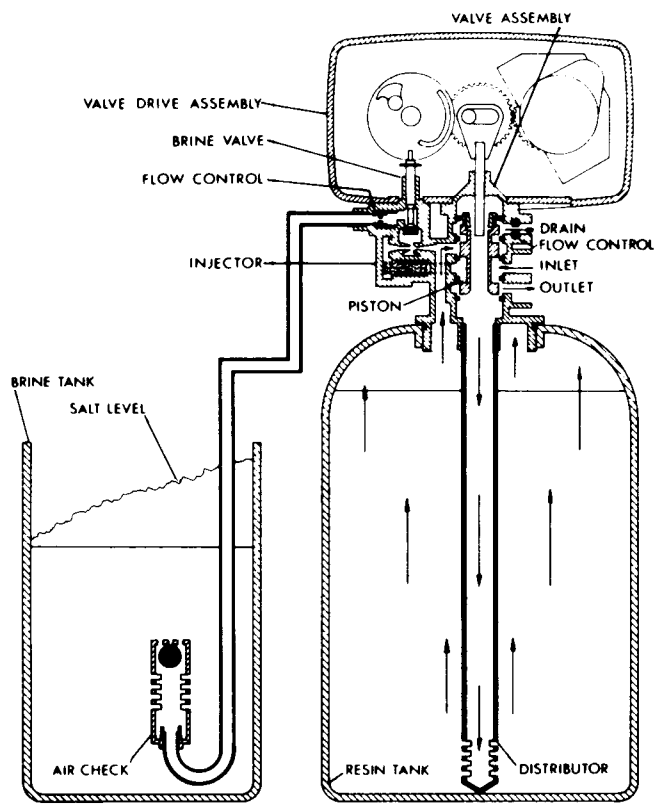

Hard water enters the unit at the valve inlet - flows around the lower piston groove and lower piston land - down thru the center tube and out the distributor - up thru the resin - thru the top of tank passage - around the upper piston groove and out the drain line.

4 BRINE POSITION

First Portion of 50 Minute Fixed Cycle

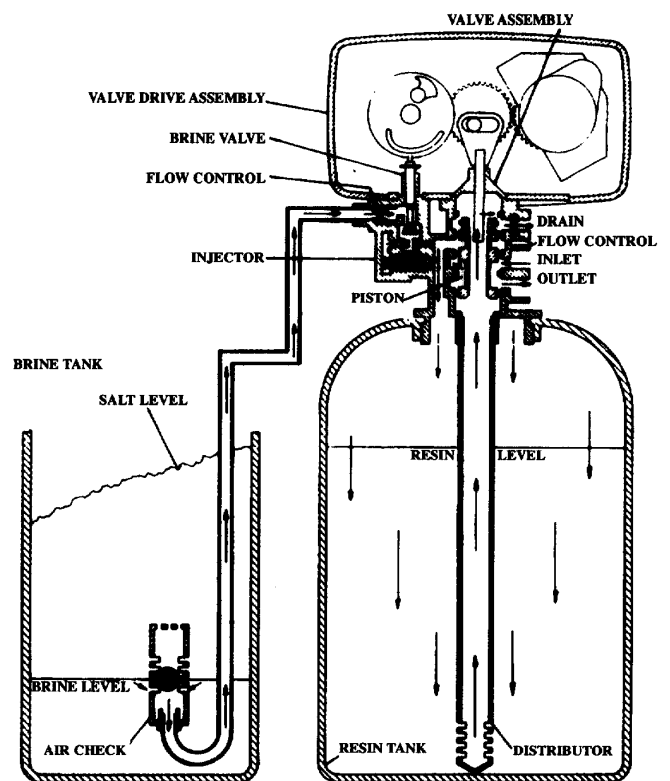

Hard water enters the unit at the valve inlet - flows around the lower piston groove - thru the injector nozzle and orifice to draw brine from the brine tank. The brine flows down thru the resin - into the distributor - up thru the center tube - thru the center hole in the piston and out the drain line.

MODEL 4650

Water Conditioner Flow Diagrams (Cont'd.)

5 SLOW RINSE POSITION

Last Portion of 50 Minute Fixed Cycle

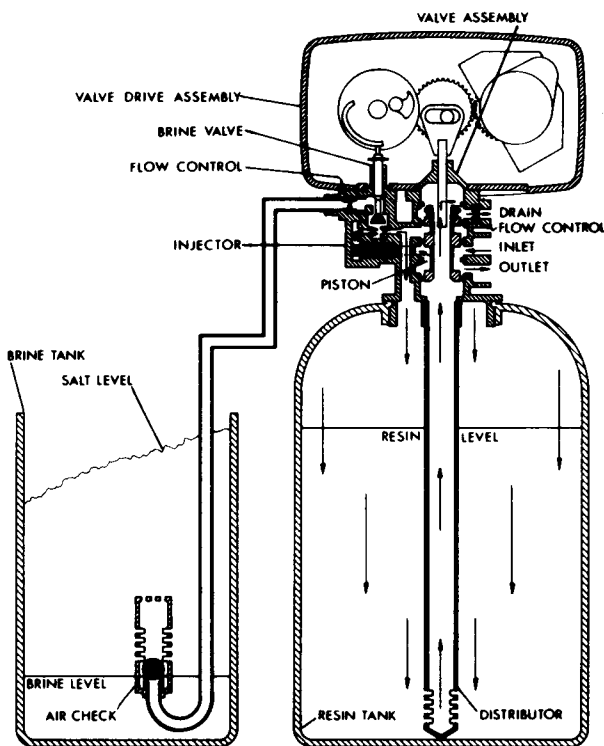

After all the brine has been drawn from the brine tank, hard water continues to enter thru the valve inlet - flows around the lower piston groove - thru the nozzle and orifice - down thru the resin and into the distributor - up thru the center tube - thru the center hole in the piston and out the drain line.

6 SECOND BACKWASH POSITION

10 Minutes

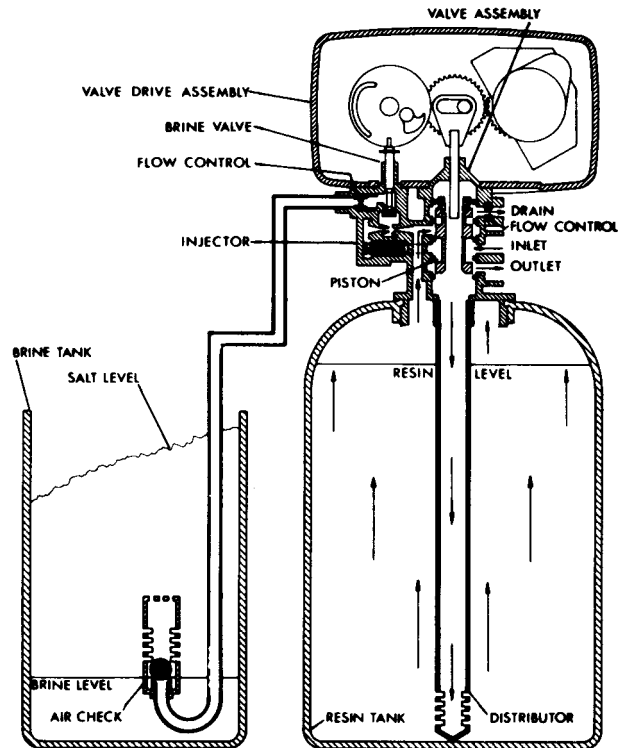

Hard water enters the unit at the valve inlet - flows around the lower piston groove and lower piston land - down thru the center tube and out the distributor - up thru the resin - thru the top of tank passage - around the upper piston groove and out the drain line.

MODEL 4650

Water Conditioner Flow Diagrams (Cont'd.)

7 SETTLING RINSE POSITION

5 Minutes

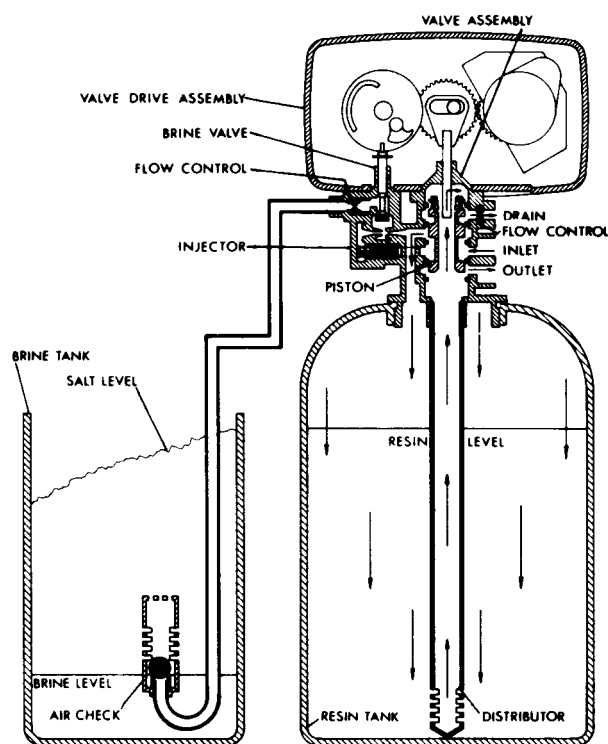

Hard water enters the unit at the valve inlet - flows around the lower piston groove - down thru the top of tank passage - downward thru the resin - up the distributor tube - thru the center hole in the piston - over the top edge of the piston and out the drain line.

8 BRINE TANK FILL POSITION

4 to 24 Minutes Adjustable Cycle

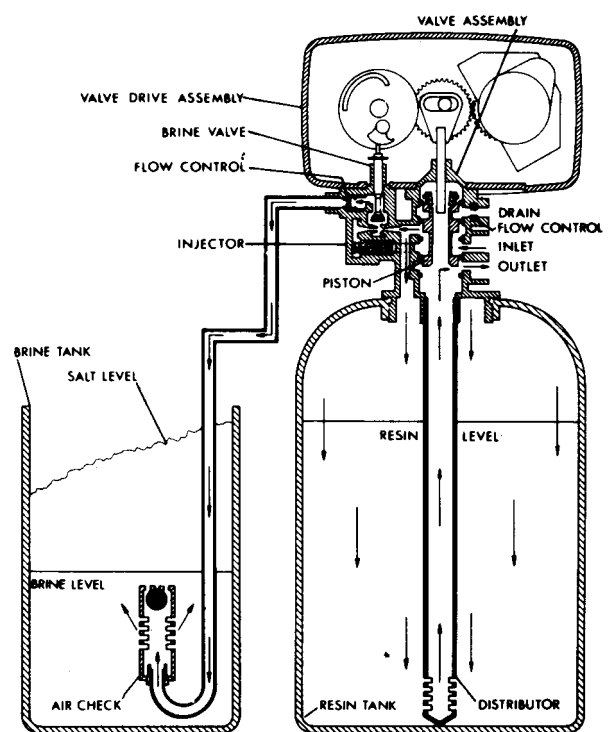

Hard water enters the unit at the valve inlet - flows around the lower piston groove - thru the injector throat - thru the brine valve and flow control to fill the brine tank. Hard water also flows around the lower piston groove - thru the passage to the top of tank - down thru the resin and enters the distributor as conditioned water. The conditioned water flows up thru the center tube to the valve outlet.

MODEL 4650

Service Instructions

PROBLEM	CAUSE	CORRECTION
1. Softener fails to regenerate.	A. Electrical service to unit has been interrupted. B. Timer is defective. C. Power failure.	A. Assure permanent electrical service (check fuse, plug, pull chain or switch). B. Replace timer. C. Reset time of day.
2. Softener delivers hard water.	A. By-pass valve is open. B. No salt in brine tank. C. Injectors or screen plugged. D. Insufficient water flowing into brine tank. E. Hot water tank hardness. F. Leak at distributor tube. G. Internal valve leak.	A. Close by-pass valve. B. Add salt to brine tank and maintain salt level above water level. C. Replace injectors and screen. D. Check brine tank fill time and clean brine line flow control if plugged. E. Repeated flushings of the hot water tank is required. F. Make sure distributor tube is not cracked. Check O-ring and tube pilot. G. Replace seals and spacers and/or piston.
3. Unit uses too much salt.	A. Improper salt setting. B. Excess water in brine tank.	A. Check salt usage and salt setting. B. See problem No. 7.
4. Loss of water pressure.	A. Iron buildup in line to water conditioner. B. Iron buildup in water conditioner. C. Inlet of control plugged due to foreign material broken loose from pipes by recent work done on plumbing system.	A. Clean line to water conditioner. B. Clean control and add resin cleaner to resin bed. Increase frequency of regeneration. C. Remove piston & clean control.
5. Loss of resin through drain line.	A. Air in water system.	A. Assure that well system has proper air eliminator control. Check for dry well condition.
6. Iron In Conditioned Water.	A. Fouled resin bed.	A. Check backwash, brine draw and brine tank fill, increase frequency of regeneration. Increase backwash time.
7a. Excessive water in brine tank.	A. Plugged drain line flow control.	A. Clean flow control.

MODEL 4650

Service Instructions (Cont'd.)

PROBLEM	CAUSE	CORRECTION
7b. Salt water in service line	A. Plugged injector system. B. Timer not cycling. C. Foreign material in brine valve. D. Foreign material in brine line flow control.	A. Clean injector and replace screen. B. Replace timer. C. Clean or replace brine valve. D. Clean brine line flow control.
8. Softener fails to draw brine.	A. Drain line flow control is plugged. B. Injector is plugged. C. Injector screen plugged. D. Line pressure is too low. E. Internal control leak.	A. Clean drain line flow control. B. Clean or replace injectors. C. Replace screen. D. Increase line pressure. (Line pressure must be at least 20 PSI at all time.) E. Change seals and spacers and/or piston assembly.
9. Control cycles continuous	A. Faulty timer mechanism	A. Replace timer.
10. Drain flows continuously.	A. Foreign material in control. B. Internal control leak. C. Control valve jammed in brine or backwash position. D. Timer motor stopped or jammed	A. Remove piston assembly and inspect bore, remove foreign material & check control in various regeneration positions. B. Replace seals and/or piston assembly. C. Replace seals and/or piston assembly. D. Replace timer.

MODEL 4650

Service Instructions (Cont'd.)

A. TO REMOVE TIME BRINE VALVE, INJECTORS, AND SCREEN

1. Unplug electrical cord from outlet.
2. Turn off water supply to conditioner:
 - a. If the conditioner installation has a "three valve" by-pass system, first open the valve in the by pass line, then close the valves at the conditioner inlet and outlet.
 - b. If the conditioner has an integral by-pass valve, put it in the by-pass position.
 - c. If there is only a shut-off valve near the conditioner inlet, close it.
3. Relieve water pressure in the conditioner by putting the control in the backwash position momentarily. Return the control to the service position.
4. Disconnect brine tube and drain line connections at the injector body.
5. Remove the two injector body mounting screws. The injector and brine module can now be removed from the control valve. Remove and discard valve body O-rings
- 6a. To Replace Brine Valve
 1. Pull brine valve from injector body, also remove & discard O-ring at bottom of brine valve hole.
 2. Apply silicone lubricant to new O-ring and reinstall at bottom of brine valve hole.
 3. Apply silicone lubricant to O- ring on new valve assembly and press into brine valve hole, shoulder on bushing should be flush with injector body.
- 6b. To replace injectors and screen.
 1. Remove injector cap and screen, discard O-ring. Unscrew injector nozzle and throat from injector body.
 2. Screw in new injector throat and nozzle, be sure they are seated tightly. Install a new screen.
 3. Apply silicone lubricant to new O-ring and install around oval extension on injector cap.
7. Apply silicone lubricant to three new O-rings and install over three bosses on injector body.
8. Insert screws with washers thru injector cap and injector. Place this assembly thru hole in timer housing and into mating holes in the valve body. Tighten screws. (Be sure to reinstall brass spacers with injector on model 4600 valve.)
9. Reconnect brine tube and drain line.
10. Return by-pass or inlet valving to normal service position. Water pressure should now be applied to the conditioner, and any by-pass line shut off.

11. Check for leaks at all seal areas. Check drain seal with the control in the backwash position.
12. Plug electrical cord into outlet.
13. Set time of day and cycle the control valve manually to assure proper function. Make sure the control valve is returned to the service position.
14. Make sure there is enough brine in the brine tank.
15. Rotate program wheel counter-clockwise until it stops at regeneration position
16. Start regeneration cycle manually if water is hard.

B. TO REPLACE TIMER

1. Unplug electrical cord from outlet.
2. Turn off water supply to conditioner:
 - a. If the conditioner installation has a "three valve" by-pass system, first open the valve in the by-pass line, then close the valves at the conditioner inlet and outlet.
 - b. If the conditioner has an integral by-pass valve, put it in the by-pass position.
 - c. If there is only a shut-off valve near the conditioner inlet, close it.
3. Relieve water pressure in the conditioner by putting the control in the backwash position momentarily. Return the control to the service position.
4. Remove the control valve back cover.
5. Remove screw and washer at drive yoke. Remove timer mounting screws. The entire timer assembly will now lift off easily.
6. Put new timer on top of valve. Be sure drive pin on main gear engages slot in drive yoke (rotate control knob if necessary).
7. Replace timer mounting screws. Replace screw and washer at drive yoke.
8. Return by-pass or inlet valving to normal service position. Water pressure should now be applied to the conditioner, and any by-pass line shut off.
9. Plug electrical cord into outlet.
10. Set time of day, program wheel, and salt usage. Cycle the control valve manually to assure proper function. Make sure the control valve is returned to the service position.
11. Replace the control valve back cover. Be sure grommet at cable hole is in place.
12. Make sure there is enough brine in the brine tank.
13. Rotate program wheel counter-clockwise until it stops at regeneration position.
14. Start regeneration cycle manually if water is hard.

MODEL 4650

Service Instructions (Cont'd.)

C. TO REPLACE PISTON ASSEMBLY

1. Unplug electrical cord from outlet.
2. Turn off water supply to conditioner:
 - a. If the conditioner installation has a "three valve" by-pass system, first open the valve in the by-pass line, then close the valves at the conditioner inlet and outlet.
 - b. If the conditioner has an integral by-pass valve, put it in the by-pass position.
 - c. If there is only a shut-off valve near the conditioner inlet, close it.
3. Relieve water pressure in the conditioner by putting the control in the backwash position momentarily. Return the control to the service position.
4. Remove the control valve back cover.
5. Remove screw and washer at drive yoke. Remove timer mounting screws. The entire timer assembly will now lift off easily. Remove end plug retainer plate.
6. Pull upward on end of piston yoke until assembly is out of valve.
7. Inspect the inside of the valve to make sure that all spacers and seals are in place, and that there is no foreign matter that would interfere with the valve operation.
8. Take new piston assembly as furnished and push piston into valve by means of the end plug. Twist yoke carefully in a clockwise direction to properly align it with drive gear. Replace end plug retainer plate.
9. Place timer on top of valve. Be sure drive pin on main gear engages slot in drive yoke (rotate control knob if necessary).
10. Replace timer mounting screws. Replace screw and washer at drive yoke.
11. Return by-pass or inlet valving to normal service position. Water pressure should now be applied to the conditioner, and any by-pass line shut off.
12. Plug electrical cord into outlet.
13. Set time of day. Cycle the control valve manually to assure proper function. Make sure the control valve is returned to the service position.
14. Replace the control valve back cover. Be sure grommet at cable hole is in place.
15. Make sure there is enough brine in the brine tank.
16. Rotate program wheel counter-clockwise until it stops at regeneration position.
17. Start regeneration cycle manually if water is hard.

D. TO REPLACE SEALS AND SPACERS

1. Unplug electrical cord from outlet.
2. Turn off water supply to conditioner:
 - a. If the conditioner installation has a "three valve" by-pass system, first open the valve in the by-pass line, then close the valves at the conditioner inlet and outlet.
 - b. If the conditioner has an integral by-pass valve, put it in the by-pass position.
 - c. If there as only a shut-off valve near the conditioner inlet, close it.
3. Relieve water pressure in the conditioner by putting the control in the backwash position momentarily. Return the control to the service position.
4. Remove the control valve back cover.
5. Remove screw and washer at drive yoke. Remove timer mounting screws. The entire timer assembly will now lift off easily. Remove end plug retainer plate.
6. Pull upward on end of piston rod yoke until assembly is out of valve. Remove and replace seats and spacers with fingers.

Notes

Notes
