

MODEL 9000

Service Manual

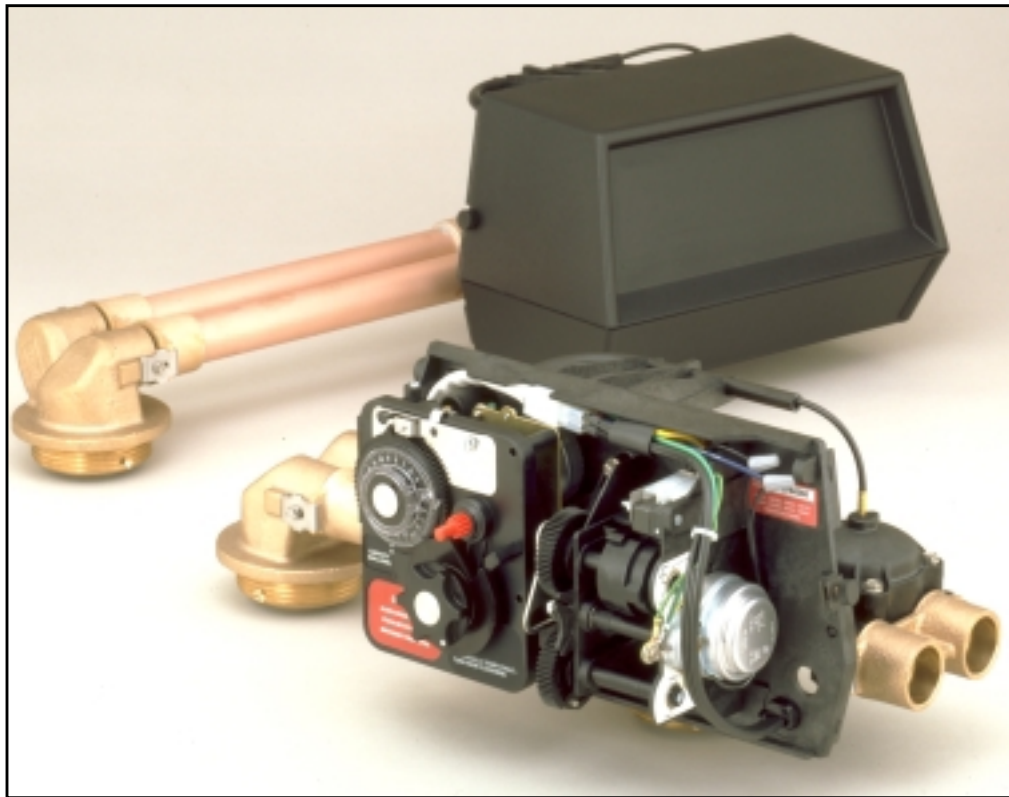

IMPORTANT: Fill in pertinent information on page 2 for future reference.

MODEL 9000 ECONOMINDER®

Job Specification Sheet

* JOB NO. _____

* MODEL NO. _____

* WATER TEST _____

* CAPACITY PER UNIT _____ MAX. _____ PER REGENERATION

* MINERAL TANK SIZE DIA. _____ HEIGHT _____

* BRINE TANK SIZE &
SALT SETTING PER REGENERATION _____

* 9000 CONTROL VALVE SPECIFICATIONS

1. Type of Timer

A) 82 minute available regeneration time, 1/15 RPM

B) 164 minute available regeneration time, 1/30 RPM

2. Type of Meter (see page 23)

A) 3/4" meter *Std. range 125 to 2,100 gal. setting
 *Ext. range 625 to 10,625 gal. setting

B) 1" meter *Std. range 310 to 5,270 gal. setting
 *Ext. range 1,550 to 26,350 gal. setting

3. Meter Gallon Setting _____ gal. (see pages 6 & 7)

4. Regeneration Program Settings (see page 5)

A) Backwash _____ min.

B) Brine & Slow Rinse _____ min.

C) Rapid Rinse _____ min.

D) Brine Tank Refill _____ min.

5. Drain Line Flow Control _____ gpm

6. Brine Refill Rate _____ gpm

7. Injector Size _____

MODEL 9000 ECONOMINDER®

General, Residential & Commercial Installation Check List

WATER PRESSURE: A minimum of 25 pounds of water pressure is required for regeneration valve to operate effectively.

ELECTRICAL FACILITIES: A continuous 110 volt, 60 Hertz current supply is required. Make certain the current supply is always hot and cannot be turned off with another switch.

EXISTING PLUMBING: Condition of existing plumbing should be free from lime and iron buildup. Piping that is built up heavily with lime and/or iron should be replaced. If piping is clogged with iron, a separate iron filter unit should be installed ahead of the water softener.

LOCATION OF SOFTENER AND DRAIN: The softener should be located close to a drain.

BY-PASS VALVES: Always provide for the installation of a by-pass valve.

CAUTION: Water pressure is not to exceed 120 p.s.i., water temperature is not to exceed 110° F, and the unit cannot be subjected to freezing conditions.

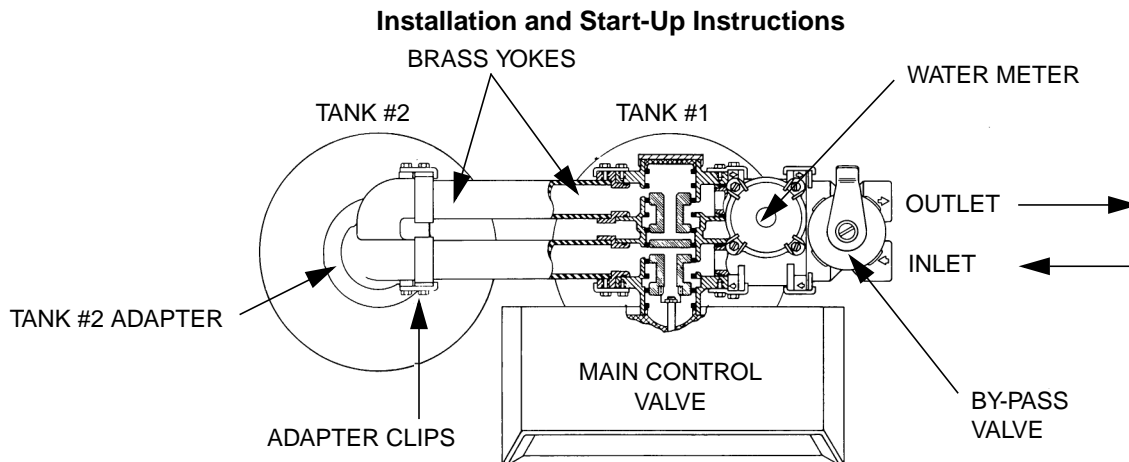

1. Place the softener tank where you want to install the unit, making sure the tanks are level and on a firm base.
2. All plumbing should be done in accordance with local plumbing codes. The pipe size for the drain line should be minimum 1/2". Overhead drains exceeding 4' above unit require 3/4" drain line.
3. Both tanks must be the same height and diameter and filled with equal amounts of media. The 1" distributor tube (1.050 O.D.) should be cut flush with top of each tank.
4. Lubricate the distributor O-Ring seal and tank O-Ring seal with silicone lubricant. Place the main control valve on one tank and the tank adapter on the second tank.
5. NOTE: The 1" copper tubing to interconnect the tanks must be soldered prior to assembly on the main control valve and tank adapter. There should be a minimum of 1" distance between tanks on final assembly.
6. Solder joints near the drain must be done prior to connecting the Drain Line Flow Control fitting. Leave at least 6" between the DLFC and solder joints when soldering. Failure to do this could cause damage to the drain module.
7. Teflon tape is the only sealant to be used on the drain fitting.
8. Make sure that the floor is clean beneath the salt storage tank and that it is level.
9. Place approximately 1" of water above the grid plate (if used) in your salt tank. Salt may be placed in the unit at this time.
10. On units with a by-pass, place in by-pass position. Turn on the main water supply. Open a cold soft water tap nearby and let run a few minutes or until the system is free from foreign material (usually solder) that may have resulted from the installation.
11. Place the by-pass in service position and let water flow into the mineral tanks. When water flow stops, open a cold water tap nearby and let run until air pressure is relieved.
12. Electrical: All electrical connections must be connected according to codes. Plug unit into electrical outlet. **Do not insert meter cable** into the meter yet.

MODEL 9000 ECONOMINDER®

General, Residential & Commercial Installation Check List (Cont'd.)

13. Tank #1 has control valve.

Tank #2 has the adapter.

Look on the right side of the control valve, it has indicators which tells you which position the control valve is in during regeneration and which tank is *IN SERVICE*. Photo on the right indicates the valve is in the service position and tank #1 is supplying conditioned water. Tank #2 is on standby.

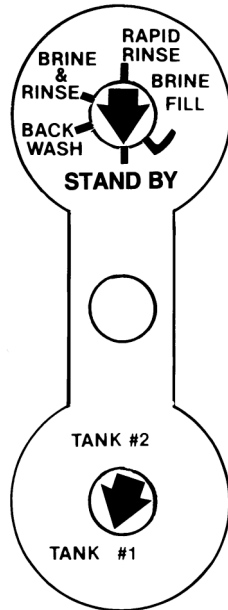

14. Cycle timer into backwash position. Turn manual knob (figure 1) so that the micro switch is riding on the 1st set of pins (figure 2). In this position the tanks will switch (lower piston) and the control valve will move to the backwash position (upper piston). *You must wait until the positioning of upper and lower pistons has stopped before advancing the timer further. If advanced too fast the control will not home into the service position (it will not advance to any other position).* To correct this, rotate the manual knob back to service and start again into backwash. **Note:** once valve has positioned itself into the backwash cycle, the homing circuit is locked in.

With all the air backwashed out, slowly cycle the timer to the brine position; rapid rinse; and brine tank refill. You must wait for the control drive motor to position itself in each cycle and stop, before advancing on to the next position.

Once back in the service position, cycle the control valve again into the backwash position. The tanks will switch again, and you will backwash the air head out of the other tank. Cycle the control back to the service position. Leave the timer in the open position.

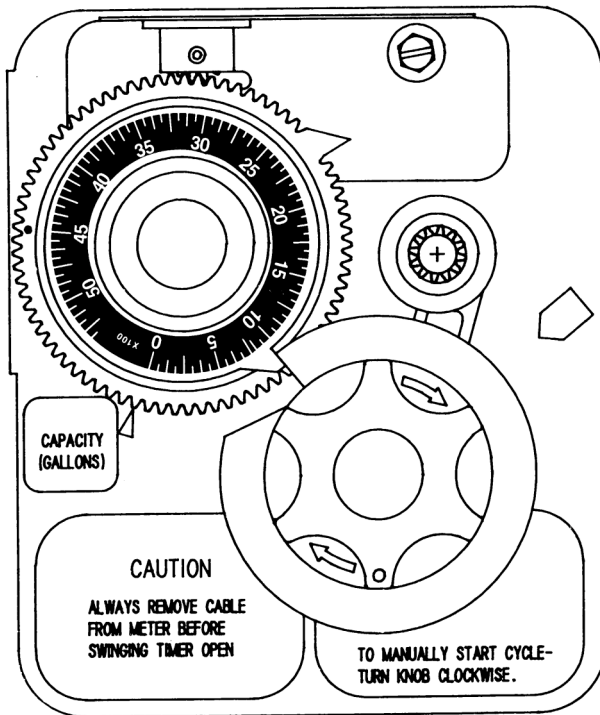

NOTE: Make sure the meter cable is not inserted in the meter dome. Swing the timer out to expose the program wheel Figure 2 (to swing timer out) grab onto the lower right corner of timer face Figure 1 and pull outward.

DO NOT INSERT METER CABLE YET.

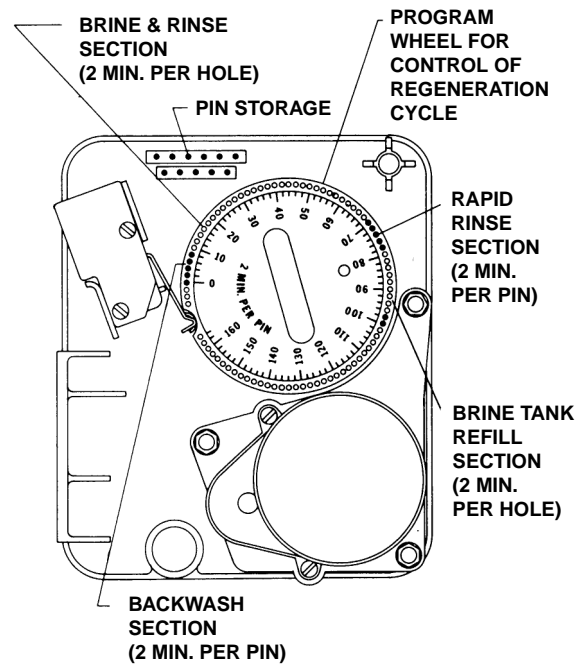

NOTE: 2 motors are available, 1/15 RPM will have a 82 min. reg. time available.

MODEL 9000 ECONOMINDER®

Regeneration Cycle Program Setting Procedure

(Brine Tank Refill Separate From Rapid Rinse)

How To Set The Regeneration Cycle Program:

The regeneration cycle program on your water conditioner has been factory preset, however, portions of the cycle or program may be lengthened or shortened in time to suit local conditions.

To expose cycle program wheel, grasp timer in lower right hand corner and pull, releasing snap retainer and swinging timer to the left. Meter cable *must* be removed from meter dome before opening timer.

To change the regeneration cycle program, the program wheel must be removed. Grasp program wheel and squeeze protruding lugs towards center, lift program wheel off timer. (Switch arms may require movement to facilitate removal.)

Return timer to closed position engaging snap retainer in back plate. Make certain all electrical wires locate above snap retainer post.

How To Change The Length Of The Backwash Time:

The program wheel as shown in the drawing is in the service position. As you look at the numbered side of the program wheel, the group of pins starting at zero determines the length of time your unit will backwash.

FOR EXAMPLE: If there are six pins in this section, the time of backwash will be 12 min. (2 min. per pin). To change the length of backwash time, add or remove pins as required. The number of pins times two equals the backwash time in minutes.

How To Change The Length Of Brine And Rinse Time:

The group of holes between the last pin in the backwash section and the second group of pins determines the length of time that your unit will brine and rinse. (2 min. per hole.)

To change the length of brine and rinse time, move the rapid rinse group of pins to give more or fewer holes in the brine and rinse section. Number of holes times two equals brine and rinse time in minutes.

How To Change The Length Of Rapid Rinse:

The second group of pins on the program wheel determines the length of time that your water conditioner will rapid rinse. (2 min. per pin.)

To change the length of rapid rinse time, add or remove pins at the higher numbered end of this section as required. The number of pins times two equals the rapid rinse time in minutes.

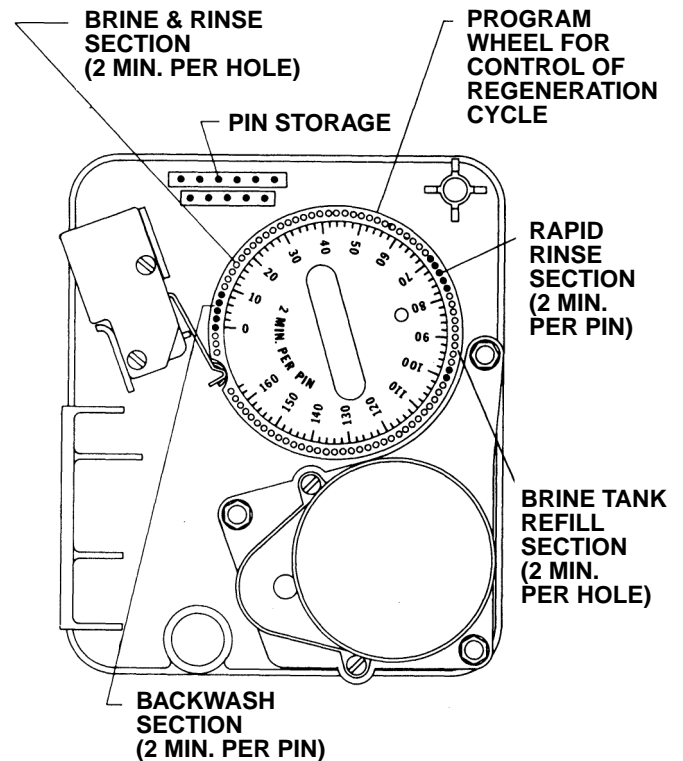

NOTE: Program wheels having 0 to 82 min. cycle times, use "1" min. per pin or hole to set regeneration times. The layout of pins and holes on the program wheel follow the same procedure as on this page.

How To Change The Length Of Brine Tank Refill Time:

The second group of holes on the program wheel determines the length of time that your water conditioner will refill the brine tank (2 min. per hole.)

To change the length of refill time, move the two pins at the end of the second group of holes as required.

The regeneration cycle is complete when the outer micro-switch is tripped by the two pin set at end of the brine tank refill section. The program wheel, however, will continue to rotate until the inner micro-switch drops into the notch on the program wheel. See page 6 for salt setting calculations, and page 24 for general timer settings.

MODEL 9000 ECONOMINDER®

Time Brine Refill & Meter Setting Procedure

PROGRAMMING

1. Your control valve has been factory set for backwash; brine and slow rinse; rapid rinse and brine tank fill times. See the control valve specification sheet (pg. 24). Any of these times can be changed by repositioning the pins and holes or adding more pins (see pg. 5). Note that two different speed timer motors are used, one allows for an 82 minute maximum regeneration time (each pin or hole = 1 min.). The other allows for 164 minute maximum regeneration time (each pin or hole = 2 min.).
2. The 9000 Control has a separate brine tank fill cycle. Your desired salt setting must be calculated, using the blue (.25 gpm) or black (.5 gpm) or red (1.0 gpm) rate of refill (in gpm) times your timer setting. Then using one gallon of fresh water dissolving approximately 3 lbs. salt, calculate your refill time.

ie: A desired 9 lb. salt setting: The unit has a .5 gpm refill rate, we will need a 3 gallon fill. (3 gal. x 3 lb./gal. = 9 lb. salt). The timer refill section would have to be set at 6 minutes. (6 min x .5 gpm = 3 gal. fill)

Note: There always must be 2 pins at the end of your refill time. This is to stop the fill cycle. With your regeneration times now set, place timer back to its original position, making sure the lower right hand corner snaps back into the backplate and the meter cable slides through the backplate and does not bind.

3. Stting the gallon wheel

Knowing the amount of resin you have in each tank and your salt setting per regeneration, calculate the gallons available, using the following capacities as a guide:

One Cubic Foot of Resin	
Salt Setting at	Capacity per Regeneration
15 lb	30,000 grains
10 lb	27,000 grains
8 lb	24,000 grains
6 lb	20,000 grains

Gallons available = $\frac{\text{Capacity per Regeneration.}}{\text{Compensated Hardness of H}_2\text{O}}$

ie: 24 grain water; each tank having 1 cubic foot of resin and salted at 8 lb. of salt, yielding a usable 24,000 grain capacity: 1,000 gallons available = $\frac{24,000 \text{ gr. capacity}}{24 \text{ gr. water}}$

DO NOT SET THIS FIGURE - GO TO STEP 4

3. Since the 9000 Valve regenerates with soft water from the other tank, you must subtract the water used for regeneration. Take each of your regeneration cycles and calculate the water used. (Use the injector Slow Rinse rate chart supplied, see pg. 24.)

ie: Unit is set up for a 10 tank having 2.4 gpm backwash, #1 injector, .5 gpm refill, timer set up for 8 min. backwash, 54 min. brine and rinse, 6 min. rapid rinse, 6 min. brine tank fill.

- A. Backwash - 8 mins. x 2.4 gpm = 19.2 gallons
- B. Brine and Rinse - 54 mins. x .33 gpm = 17.8 gallons
(See injector chart slow rinse flow, pg. 23)
- C. Rapid Rinse - 6 mins. x 2.4 gpm = 14.4 gallons
- D. Brine Tank Fill - 6 mins. x .5 gpm = 3.0 gallons

Total Regeneration Water = 54.4 gallons

MODEL 9000 ECONOMINDER®

Time Brine Refill & Meter Setting Procedure (Cont'd.)

If we have 1000 gallons available from Step 3, we want to subtract the regeneration water used from the total water available.

1000 gallons available - 55. gallons used = 945 gallons setting (in regeneration)

4. **NOW** set Meter wheel at approximately 950 gallons. Lift the inner dial of the meter program wheel so that you can rotate it freely. Position the white dot opposite the 950 gallon setting (see diag. below).

NOTE: There is a slight delay time from the time the meter zero's out and when the cycle starts. Units using the 1/15 rpm motor, 82 minute regeneration time available (tanks 6" thru 12") have a *9 minute delay*. Units using the 1/30 rpm motor, 180 minute regeneration time available (tanks 13" and larger) have an *18 minute delay*. Typically on residential equipment this delay period is not critical. On commercial applications, this must be taken into consideration and continuous flows for 9 minutes or 18 minutes should be subtracted from water available.

- NOW**
1. Insert Meter cable into Meter.
 2. Check Bypass.
 3. Plug unit in.

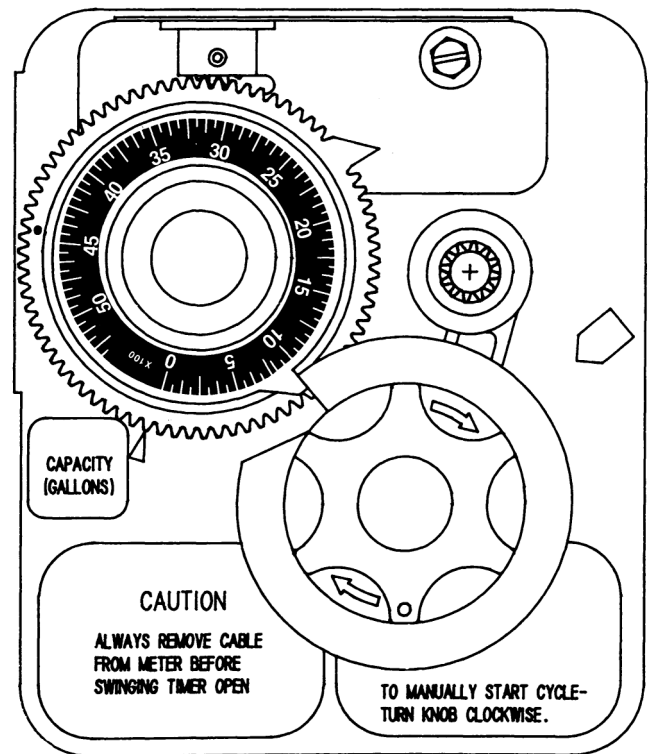

MODEL 9000 ECONOMINDER®

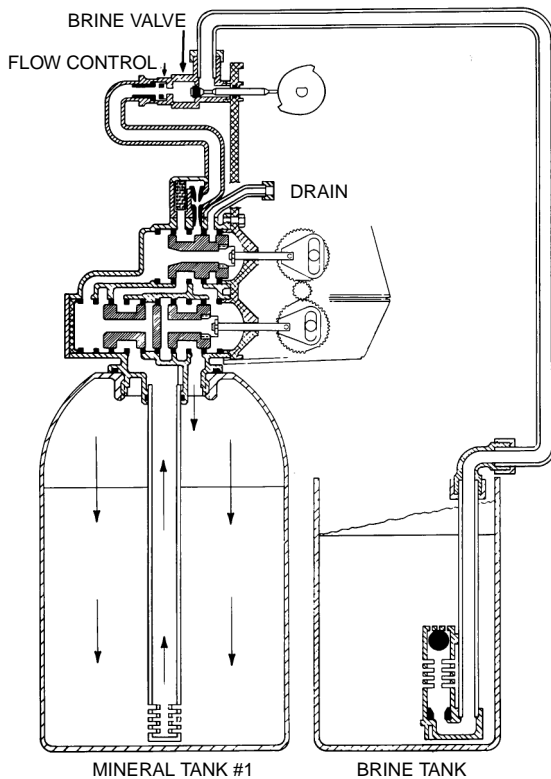

1 - SERVICE POSITION

Hard water enters the unit at the valve inlet, flows around the lower piston, and down through the mineral in the first tank. Conditioned water enters the center tube through the bottom distributor, flows up through the center tube, around the lower piston, through the meter, and out the valve outlet. The second mineral tank is regenerated and on standby.

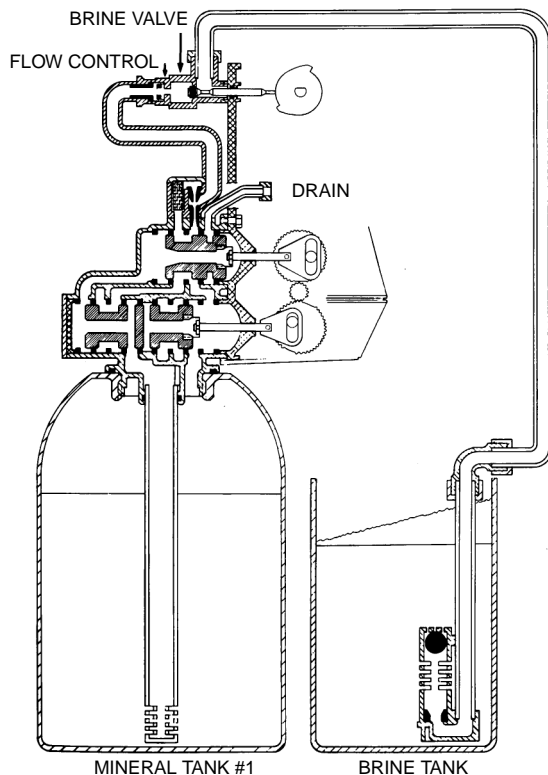

2 - TANKS SWITCHING (the meter has initiated a regeneration)

Hard water enters the unit at the valve inlet, flows around the lower piston, through the pipe leading to the second mineral tank, and down through the mineral in the second tank. Conditioned water enters the center tube of the second tank through the bottom distributor, flows up through the center tube, through the pipe leading back to the main valve, around the lower piston, through the meter, and out the valve outlet. The depleted first mineral tank is out of the flow path, and ready for regeneration.

MODEL 9000 ECONOMINDER®

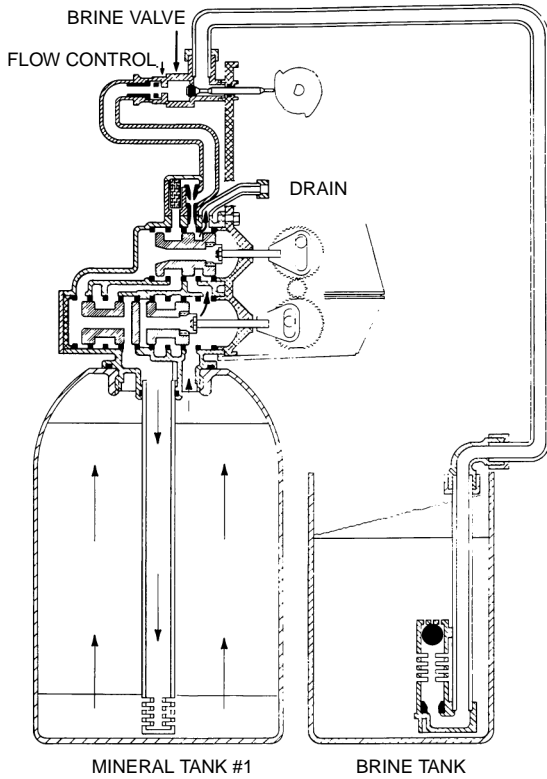

3 - BACKWASH

Conditioned water from the second mineral tank flows around the lower piston, around the upper piston, through the center of the lower piston, down the center tube, up through the mineral, around the upper piston, and out the drain line.

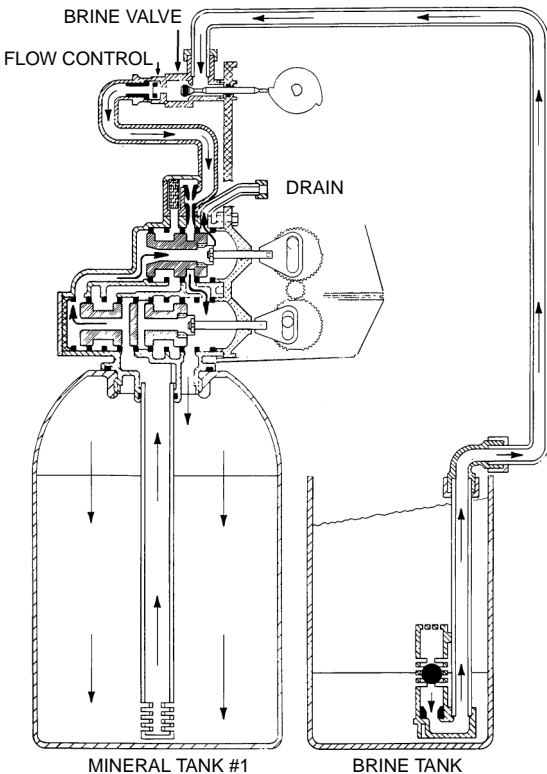

4 - BRINE DRAW

Conditioned water from the second mineral tank flows around the lower piston, around the upper piston, into the injector housing, and down through the nozzle and throat to draw brine from the brine tank. Brine flows around the upper piston, down through the mineral, into the center tube through the bottom distributor, up the center tube, through the center of the lower piston, through the center of the upper piston, and out through the drain line.

MODEL 9000 ECONOMINDER®

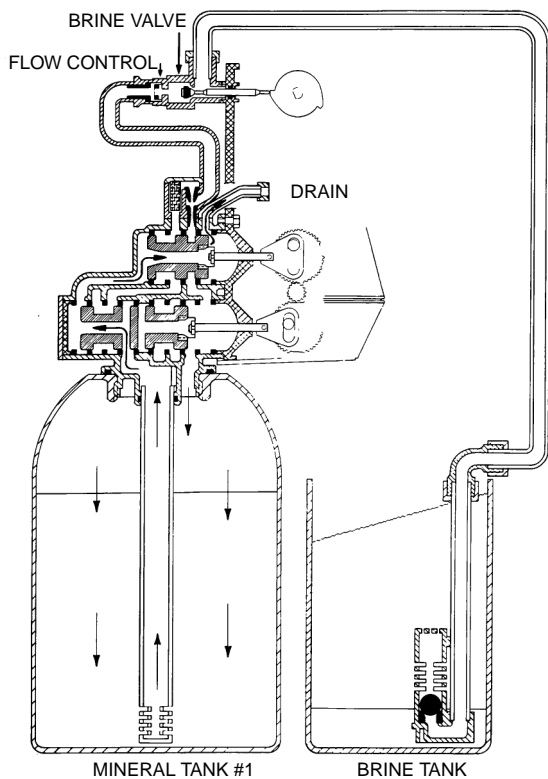

5 - SLOW RINSE

Conditioned water from the second mineral tank flows around the lower piston, around the upper piston, into the injector housing, down through the nozzle and throat, around the upper piston, down through the mineral, into the center tube through the bottom distributor, up the center tube, through the center of the lower piston, through the center of the upper piston, and out through the drain line.

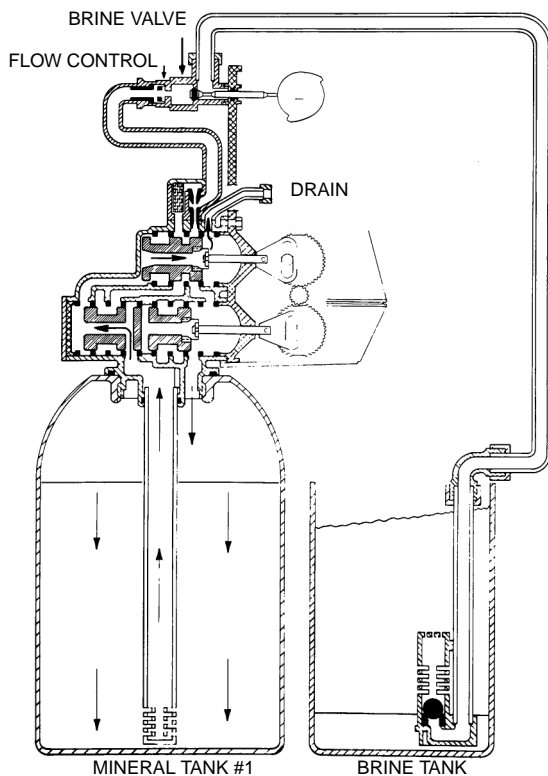

6 - RAPID RINSE

Conditioned water from the second mineral tank flows around the lower piston, around the upper piston, and down through the mineral in the first tank. Rinse water from the mineral bed enters the center tube through the bottom distributor, flows up the center tube, through the center of the lower piston, through the center of the upper piston, and out through the drain line.

MODEL 9000 ECONOMINDER®

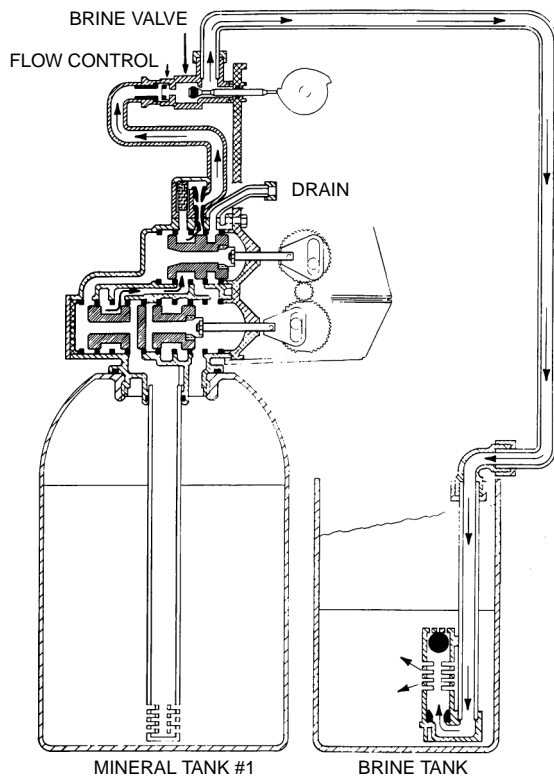

7 - BRINE TANK FILL POSITION

Conditioned water from the second mineral tank flows around the lower piston, around the upper piston, into the injector housing, through the brine line flow control, through the brine valve, and into the brine tank. No water flows through the first mineral tank.

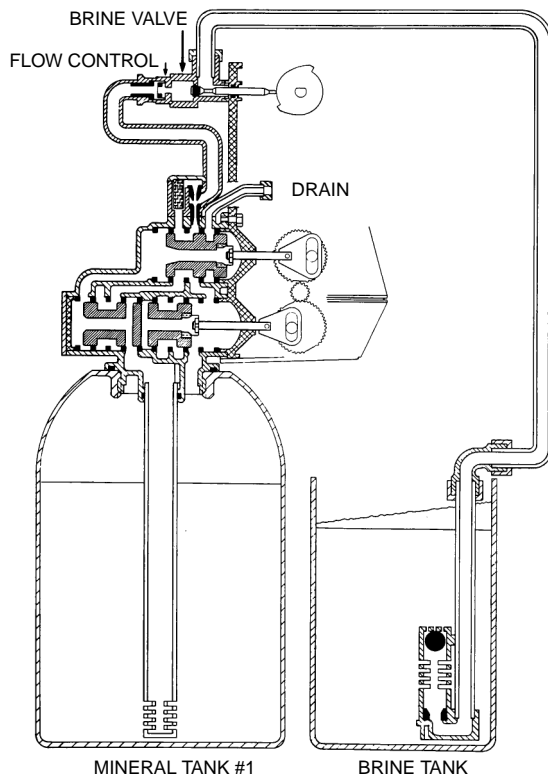

8 - SERVICE (TANKS SWITCHED)

Hard water enters the unit at the valve inlet, flows around the lower piston, through the pipe leading to the second mineral tank, and down through the mineral in the second tank. Conditioned water enters the center tube of the second tank through the bottom distributor, flows up through the center tube, through the pipe leading back to the main valve, around the lower piston, through the meter, and out the valve outlet. The regenerated first mineral tank is out of the flow path, and ready for use when the second mineral tank becomes depleted.

MODEL 9000 ECONOMINDER®

Drive Assembly

(See opposite page for parts list)

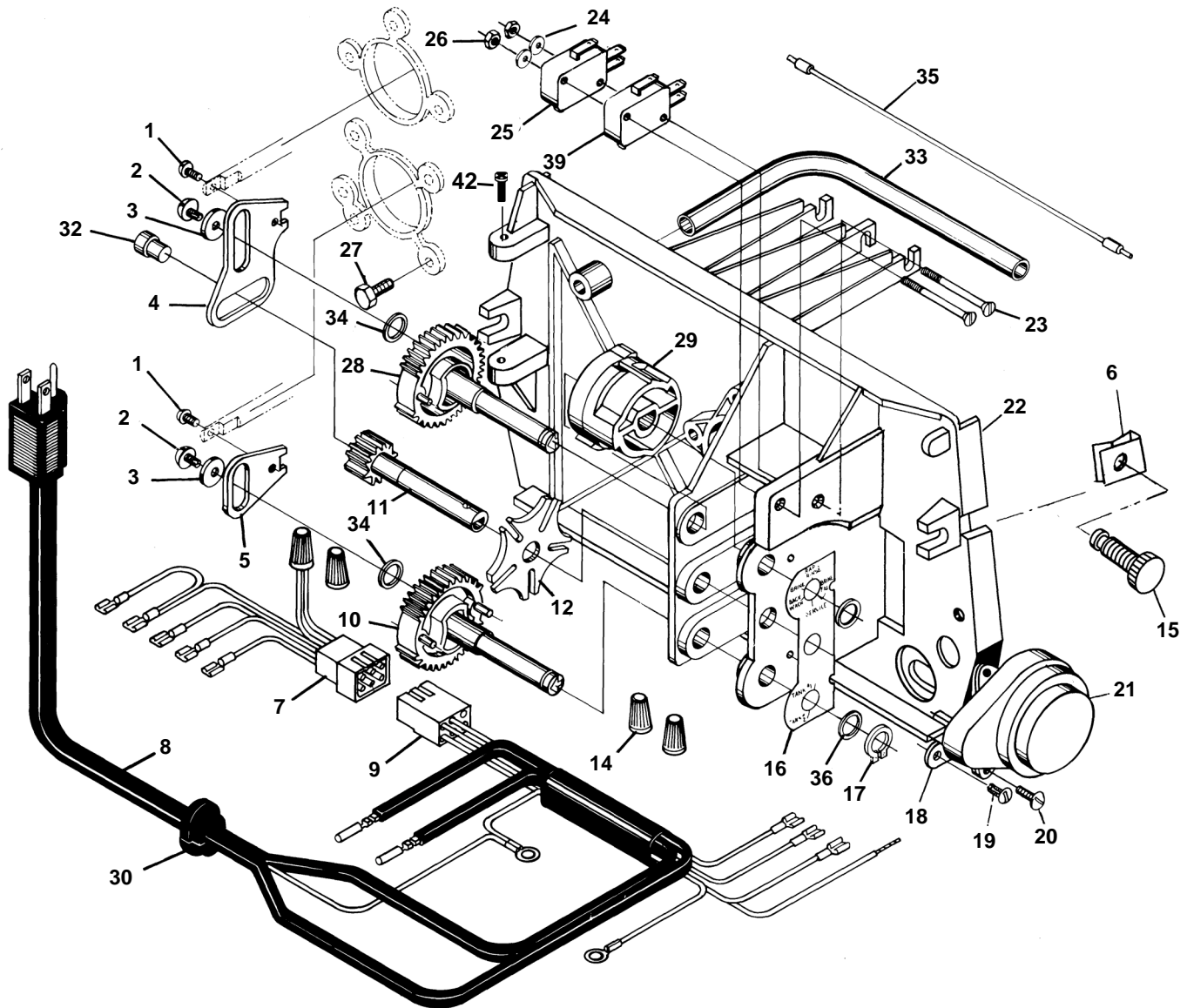

MODEL 9000 ECONOMINDER®

Drive Assembly

Parts List

Item No.	Quantity	Part No.	Description
1	2	11335	Screw, #4-40
2	2	18564	Screw, Hex Washer #6-20
3	2	13363	Washer
4	1	14921	Piston Rod Link, Upper
5	1	15019	Piston Rod Link, Lower
6	2	18728	Nut, Clip, #8-32
7	1	15203	Wiring Harness - Timer
8	1	11838	Power Cord
9	1	15202	Wiring Harness - Drive
10	1	15134	Drive Gear, Assembly, Lower
11	1	15135	Drive Gear
12	1	14896	Geneva Wheel
14	4	12681	Wire Connector
15	2	19367	Cover Screw Assembly
16	1	15175	Position Decal
17	2	14917	Retaining Ring
18	1	15199	Ground Plate
19	1	14430	Screw, Hex Washer #6
20	2	13602	Screw, Round Hd #6-32
21	1	18739	Drive Motor - 220V., 50 Hz
	1	18738	Drive Motor - 120V., 60 Hz
	1	18737	Drive Motor 24V., 50-60 Hz
22	1	15131	Control Panel
23	2	15172	Screw, Flat Hd #4-40
24	2	10340	Washer, Lock #4
25	1	10218	Micro Switch
26	2	10339	Nut, Hex #4-40
27	7	15331	Screw, Hex Washer #10-24
28	1	15133	Drive Gear, Assembly, Upper
29	1	15132	Triple Cam
30	1	13547	Strain Relief
31	1	15810	Retaining Ring, Drive Gear (not shown)
32	1	15323	Guide Pin Upper Piston Rod Link
33	1	15368	Cable Guide
34	2	15372	Washer, Thrust
35	1	15216	Meter Cable Assy. - 1" Meter
	1	15425	Meter Cable Assy. - 3/4" Meter
36	2	15692	Spacer
37	1	10302	Insulator (not shown)
38			Not Assigned
39	1	16433	Micro Switch, Program
40	1	18699-XX	Cover, Top (Now Shown)
41	1	14779-XX	Cover, Bottom (Not Shown)
	1	19291-020	Cover, 1 Piece, Black
42	2	15173	Screw

MODEL 9000 ECONOMINDER®

Control Valve Assembly

(See opposite page for parts list)

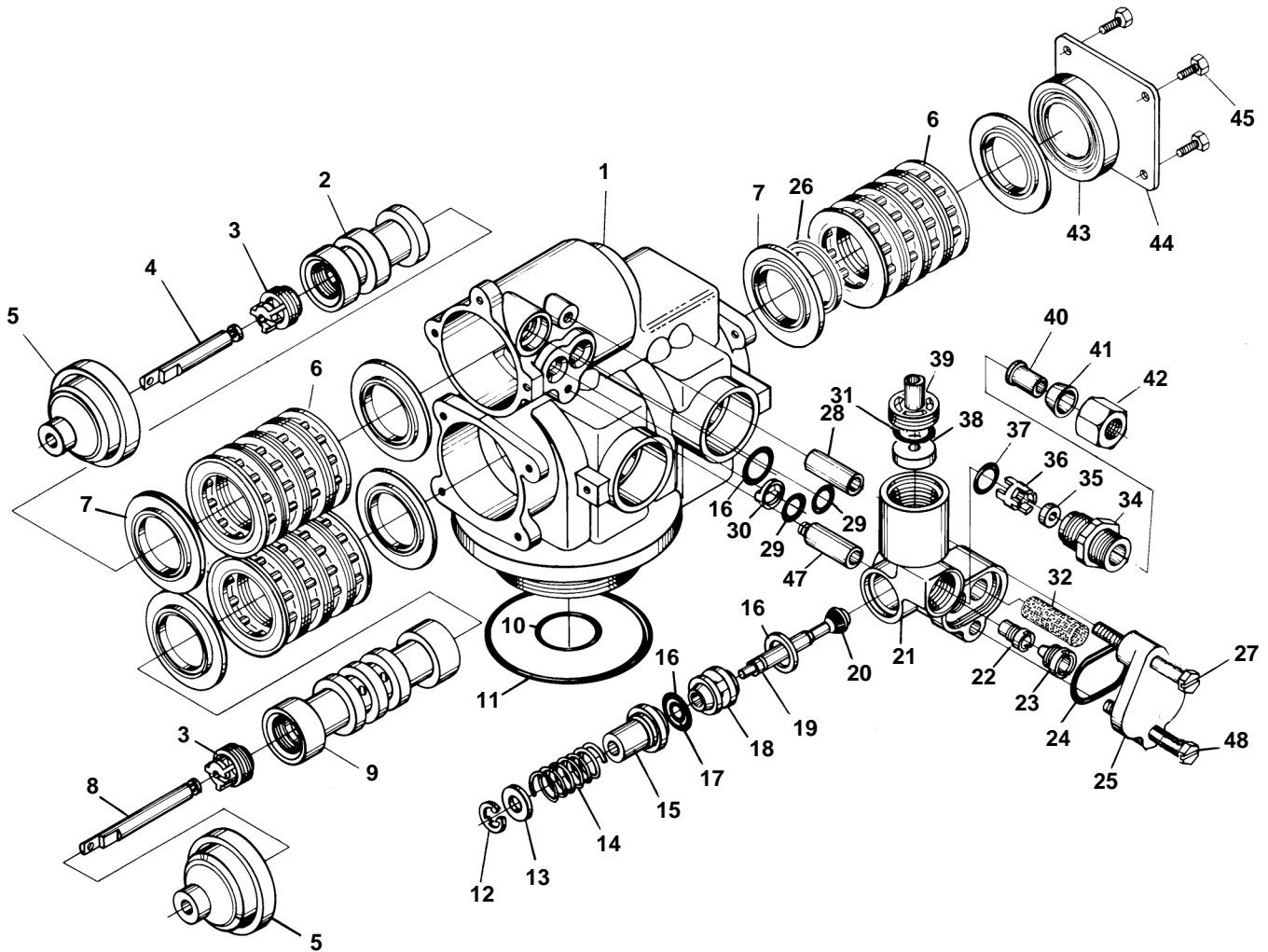

MODEL 9000 ECONOMINDER®

Control Valve Assembly

Parts List

Item No.	Quantity	Part No.	Description
1	1	14861-01	Valve Body
2	1	14914	Piston, Upper
3	2	14309	Piston Rod Retainer
	2	16590	Piston Rod Retainer, HW
4	1	14919	Piston Rod, Upper
5	2	13446	End Plug Assy.
	2	13446-01	End Plug Assy., HW
6	12	14241	Spacer
	12	14241-01	Spacer, HW
7	16	13242	Seal
	16	18759	Seal, HW
8	1	14920	Piston Rod, Lower
9	1	14905	Piston, Lower
10	1	11710	O-Ring, -215
11	1	12281	O-Ring, -338
12	1	11981-01	Retaining Ring
13	1	16098	Washer, Brine Valve (Nylon)
14	1	11973	Spring, Brine Valve
15	1	13165	Brine Valve Cap
16	3	13302	O-Ring, -014
17	1	12550	Quad Ring, -009
18	1	13167	Brine Valve Spacer
19	1	14925	Brine Valve Stem
20	1	12626	Brine Valve Seat
21	1	15215	Injector Body
22	1	10914	Injector Throat - Specify Size pg. 24
		10226	Injector Throat, SS
23	1	10913	Injector Nozzle, Specify Size pg. 24
		10225	Injector Nozzle, SS
24	1	13303	O-Ring, -021
25	1	13166	Injector Cover
26	1	16595	Spacer
27	1	13387	Screw, Hex Hd #10-24
28	1	13361	Spacer, Injector
29	2	13301	O-Ring, -011
30	1	13497	Air Disperser
31	1	15348	O-Ring, -563
32	1	10227	Injector Screen
33			Not Assigned
34	1	13244	B.L.F.C. Fitting
37	1	16173	B.L.F.C. Fitting - Bored*
35	1		B.L.F.C. Button - Specify Size pg. 24
36	1	13245	B.L.F.C. Button Retainer
	1	12977	O-Ring, -015
38	1		D.L.F.C. Button - Specify Size pg. 24
39	1	13173	D.L.F.C. Button Retainer
40	1	10332	Tube Insert - 3/8"
	1	15415	Tube Insert - 1/2"
41	1	10330	Ferrule - 3/8"
	1	16124	Ferrule - 1/2"
42	1	10329	Tube Nut - 3/8"
	1	16123	Tube Nut - 1/2"
43	1	14928	Stub End Plug
44	1	14906	End Plate
45	4	15137	Screw, Hex Washer, #10-24
46	1	16140	Adapter, 1/2" T to 1/4" P (not shown)*
47	1	15471	Brine Valve Stand Off
48	1	13315	Screw, Hex Washer, #10-24

Note: For Hot Water Delete Items 41 & 42 and use
 18698 . .Nut & Sleeve Assy. 3/8"
 15414 . .Nut & Sleeve Assy. 1/2"

* These parts are used with #4 Injector and 2 GPM or larger Brine Line Flow Control (B.L.F.C.). Items 34, 35 and 36 are not used.

MODEL 9000 ECONOMINDER®

Second Tank Adapter Assembly

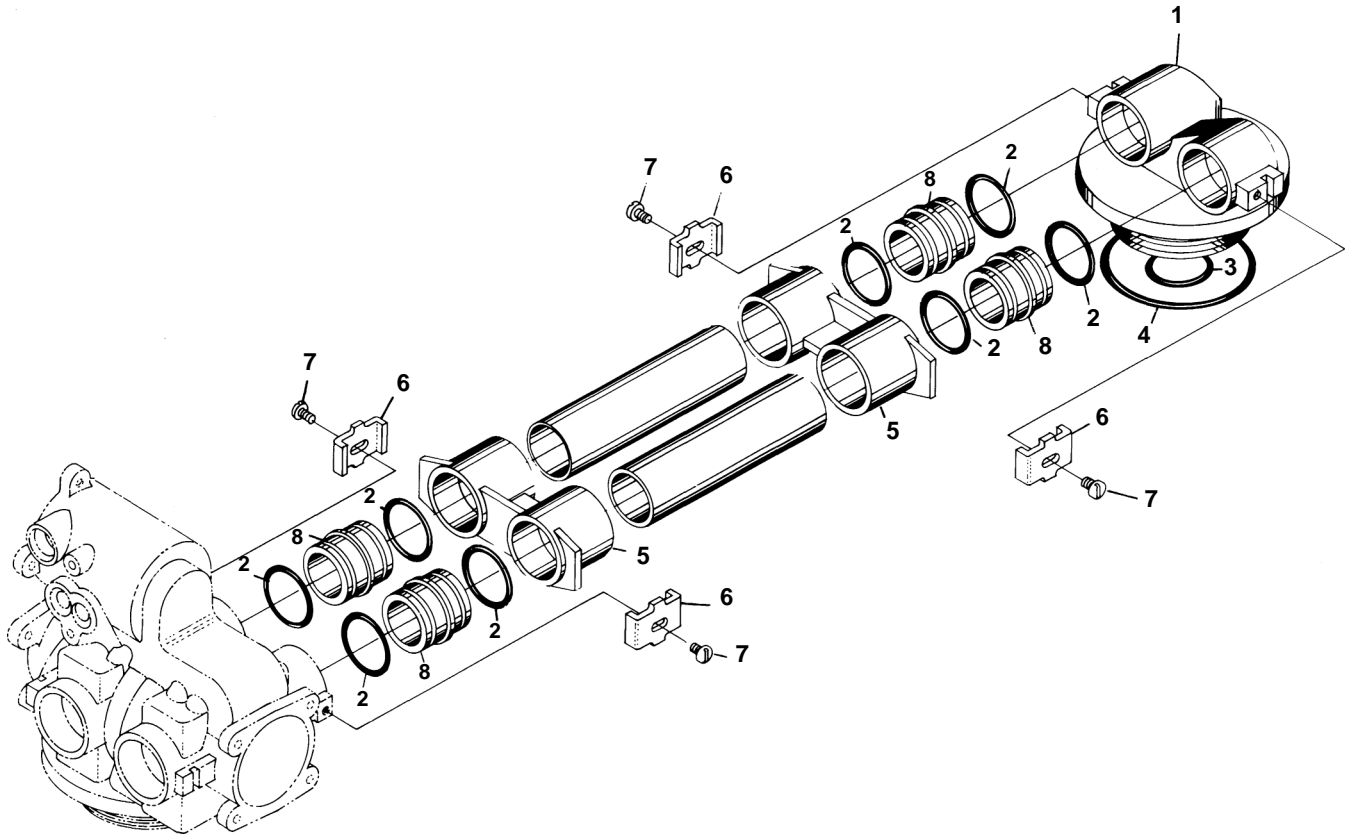

PARTS LIST

Item No.	Quantity	Part No.	Description
1	1	14864-01	2nd Tank Adapter
2	8	13305	O-Ring, -119
3	1	11710	O-Ring, -215
4	1	12281	O-Ring, -338
5	2	13708-40	Yoke
	1	15823-XX	Yoke Assy. Specify Tank Size
6	4	13255	Hold-Down Clip
7	4	14202	Screw, Hex Hd #8-32
8	4	15078	Coupling
9	2		Pipe - 1" Copper Cut to Length

MODEL 9000 ECONOMINDER®

Air Check

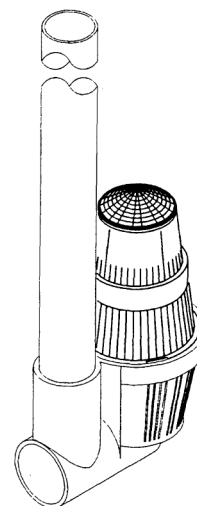
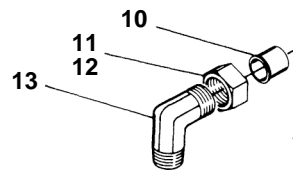
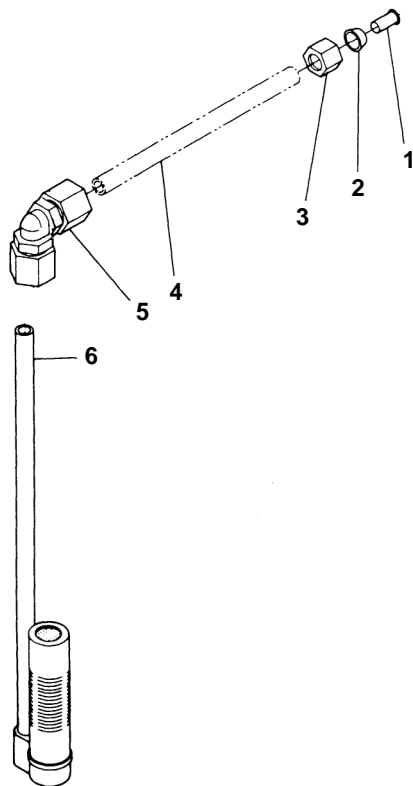

PARTS LIST

Item No.	Quantity	Part No.	Description
1.....	1	10332	Tube Insert 3/8"
2.....	1	10330	Ferrule 3/8"
3.....	1	10329	Tube Nut 3/8"
4.....	1	Not Supplied	Brine Line Tube (3/8 Flexible Tube)
5.....	1	12794	90° Elbow - 3/8" T to 3/8" T
	1	13555	90° Elbow - 3/8" T to 3/8" T, HW
6.....	1	60002	#500 Air Check Assembly
	1	60003	#500 Air Check Assembly, HW

For Use With 2 GPM Flow Control

10	15415	Tube Insert 1/2"
11	16123	Ferrule 1/2"
12	16124	Tube Nut 1/2"
13	15413	Elbow
14	60009	#900 Air Check Assembly
	60009-01	#900 Air Check Assembly, HW

MODEL 9000 ECONOMINDER®

1" Meter Assembly

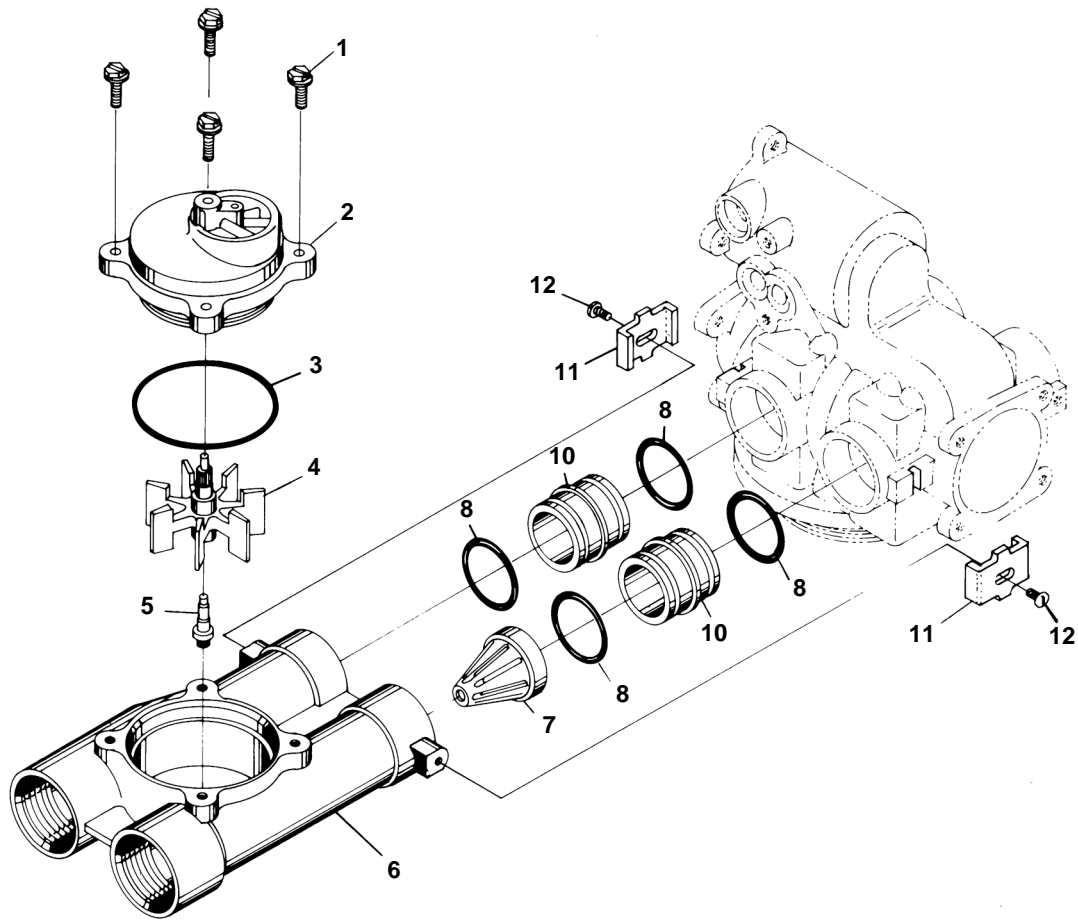

PARTS LIST

Item No.	Quantity	Part No.	Description
1	4	12112	Screw, Hex Hd #10-24
2	1	15218	Meter Cover Assy.
		15237	Meter Cover Assy. (Ext. range)
3	1	13847	O-Ring, -137
4	1	13509	Impeller
	1	13509-01	Impeller, HW
5	1	13882	Impeller Post
6	1	15043	Meter Body 1" - 11-1/2 N.P.T.
	1	15043-10	Meter Body 1" - 11 B.S.P.
7	1	14960	Flow Straightener
8	4	13305	O-Ring, -119
9			Not Assigned
10	2	15078	Coupling
11	2	13255	Adapter Clip
12	2	14202	Screw, Hex Hd #8-32

MODEL 9000 ECONOMINDER®

3/4" Meter Assembly

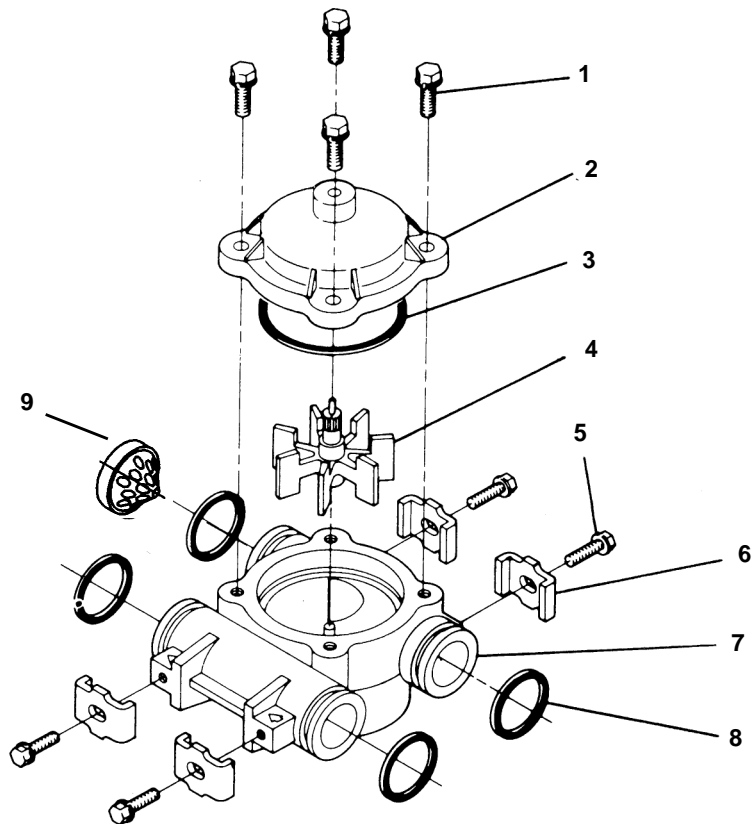

PARTS LIST

Item No.	Quantity	Part No.	Description
1.....	4	12473	Screw, Hex Washer #10-24
2.....	1	14038	Meter Cover Assembly - Standard
		15150	Meter Cover Assembly - Extended Range
3.....	1	13847	O-Ring, -137
4.....	1	13509	Impeller
5.....	4	13314	Screw, Hex Washer #8-18
6.....	4	13255	Adapter Clip
7.....	1	13821	Meter Body
8.....	4	13305	O-Ring, -119
9.....	1	14613	Flow Straightener

MODEL 9000 ECONOMINDER®

Timer Assembly

(See opposite page for parts list)

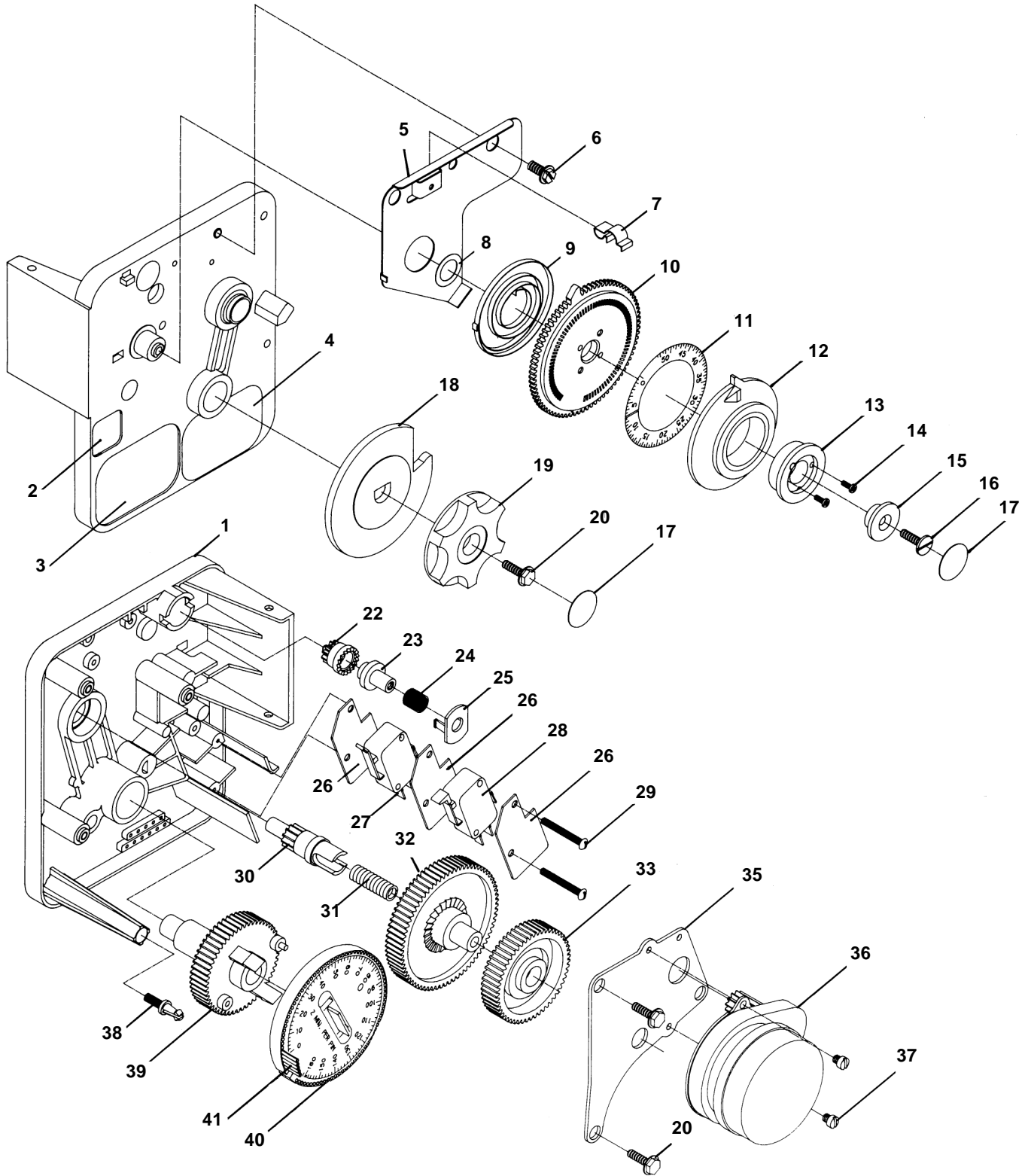

MODEL 9000 ECONOMINDER®

Timer Assembly

Parts List

Item No.	Quantity	Part No.	Description
1	1	13870-03	Timer Housing Assy.
2	1	17870	Label - Capacity Gallons
3	1	15465	Label - Caution
4	1	16930	Label - Instruction
5	1	15227	Actuator Plate
6	1	10300	Screw, Hex Washer #8
7	1	17513	Spring Clip
8	1	15407	Washer, Plain #4
9	1	15228	Spring
10	1	15224-01	Drive Gear - Program Wheel
11	1	15967	Gallon Label 3/4" Meter
		15968	Gallon Label 3/4" Meter - Ext. Range
		15969	Gallon Label 1" Meter
		15970	Gallon Label 1" Meter - Ext. Range
12	1	15956	Adjusting Disc
13	1	16218	Program Wheel Cover
14	2	17054	Screw, #4-40
15	1	13806	Program Wheel Retainer
16	1	13748	Screw, Flat Hd #6-20
17	2	11999	Button Decal
18	1	15223	Cycle Actuator Gear
19	1	13886-01	Knob
20	4	13296	Screw, Hex Washer #6-20
22	1	17724	Drive Pinion
23	1	17723	Drive Pinion Clutch
24	1	14276	Spring - Meter Clutch
25	1	14253	Retainer
26	3	14087	Insulator
27	1	15314	Switch
28	1	15320	Switch
29	2	11413	Screw, Pan Hd #4-40
30	1	13018	Idler Shaft
31	1	18563	Spring - Idler Shaft
32	1	13017	Idler Gear
33	1	13164	Drive Gear
35	1	13887	Motor Mtg. Plate
36	1	18743	Motor - 120V 60 Hz. - 1/30 RPM
		18824	Motor - 220V 50 Hz. - 1/30 RPM
		19170	Motor - 120V 60 Hz. - 1/15 RPM
		18825	Motor - 220V 50 Hz. - 1/15 RPM
		19169	Motor - 24V 60Hz - 1/15 RPM
		19168	Motor - 24V 50Hz - 1/15 RPM
37	2	13278	Screw, #6-32
38	1	14265	Spring Clip
39	1	15055	Main Drive Gear
40	1	19210-05	Program Wheel Assembly - 180 min.
	1	19210-02	Program Wheel Assembly - 90 min.
41	23	15493	Roll Pin
42			Not Assigned
43	1	14430	Screw, Hex Washer, #6 (Ground, Nut Shown)
		15203	Harness
		12681	Wire Nuts

MODEL 9000 ECONOMINDER®

Service Instructions

PROBLEM	CAUSE	CORRECTION
1. Softener Fails To Regenerate.	A. Electrical Service To Unit Has Been Interrupted. B. Timer Is Defective.	A. Assure Permanent Electrical Service (Check Fuse, Plug, Pull Chain or Switch). B. Replace Timer.
2. Hard Water.	A. By-Pass Valve is Open. B. No Salt in Brine Tank. C. Injector Screen Plugged. D. Insufficient Water Flowing Into Brine Tank E. Hot Water Tank Hardness. F. Leak At Distributor Tube. G. Internal Valve Leak.	A. Close By-Pass Valve. B. Add Salt To Brine Tank and Maintain Salt Level Above Water Level. C. Clean Injector Screen. D. Check Brine Tank Fill Time And Clean Brine Line Flow Control If Plugged. E. Repeated Flushings Of The Hot Water Tank is Required. F. Make Sure Distributor Tube Is Not Cracked. Check O-Ring And Tube Pilot. G. Replace Seals and Spacers And/Or Piston.
3. Unit Used Too Much Salt.	A. Improper Salt Setting. B. Excessive Water in Brine Tank.	A. Check Salt Usage and Salt Setting. B. See Problem No. 7.
4. Loss Of Water Pressure.	A. Iron Buildup In Line To Water Conditioner. B. Iron Buildup In Water Conditioner. C. Inlet of Control Plugged Due to Foreign Material Broken Loose From Pipes By Recent Work Done On Plumbing System.	A. Clean Line To Water Conditioner. B. Clean Control and Add Mineral Cleaner to Mineral Bed. Increase Frequency of Regeneration and/or Backwash Time. C. Remove Pistons and Clean Control.
5. Loss of Mineral Through Drain Line.	A. Air In Water System.	A. Assure That Well System Has Proper Air Eliminator Control. Check For Dry Well Condition.
6. Iron In Conditioned Water.	A. Fouled Mineral Bed.	A. Check Backwash, Brine Draw And Brine Tank Fill. Increase Frequency Of Regeneration.
7. Excessive Water In Brine Tank.	A. Plugged Drain Line Flow Control. B. Plugged Injector System. C. Timer Not Cycling.	A. Clean Flow Control. B. Clean Injector and Screen. C. Replace Timer.

MODEL 9000 ECONOMINDER®

Service Instructions (Cont'd.)

PROBLEM	CAUSE	CORRECTION
8. Softener Fails To Draw Brine.	D. Foreign Material In Brine Valve.	D. Replace Brine Valve Seat And Clean Valve.
	E. Foreign Material In Brine Line Flow Control.	E. Clean Brine Line Flow Control.
	F. Power Loss During Brine Fill.	F. Check Power Source.
	A. Drain Line Flow Control Is Plugged.	A. Clean Drain Line Flow Control.
	B. Injector Is Plugged.	B. Clean Injector.
	C. Injector Screen Plugged.	C. Clean Screen.
9. Control Cycles Continuously.	D. Line Pressure Is Too Low.	D. Increase Line Pressure To 25 P.S.I. Min.
	E. Internal Control Leak.	E. Change Seals, Spacers and Piston Assembly.
	A. Broken or Shorted Switch.	A. Determine If Switch or Timer Is Faulty and Replace it or Replace Complete Power Head.
10. Drain Flows Continuously.	A. Valve Is Not Programming Correctly.	A. Check Timer Program and Positioning of Control. Replace Power Head Assembly If not Positioning Properly.
	B. Foreign Material In Control.	B. Remove Power Head Assembly And Inspect Bore, Remove Foreign Material and Check Control In Various Regeneration Positions.
	C. Internal Control Leak.	C. Replace Seals and Piston Assembly.

General Service Hints

Problem: Softener Delivers Hard Water.

Cause could be that . . . Reserve Capacity Has Been Exceeded.

Correction: Check salt dosage requirements and reset program wheel to provide additional reserve.

Cause could be that . . . Program Wheel Is Not Rotating With Meter Output.

Correction: Pull cable out of meter cover and rotate manually. Program wheel must move without binding and cycle actuator must start the cycle before the clutch releases.

Cause could be that . . . Meter Is Not Measuring Flow.

Correction: Check output by observing rotation of small gear on front of timer (Note — program wheel must not be against regeneration stop for this check). Each tooth is approximately 75 gallons on 1" installations. If not performing properly, replace meter.

Cause could be that . . . Trip Dog On Program Wheel Is Beyond Cycle Actuator Arm.

- Correction:**
1. If power failed during regeneration; reset program wheel and cycle manually.
 2. If exceeding system capacity before regeneration was completed; either a) increase system capacity, b) restrict flow rates, or c) change timer from 164 min./cycle to 82 min./cycle.
 3. If defective timer; replace timer.

MODEL 9000 ECONOMINDER®

2 Tank Wiring & Control Information

9000 WIRING DIAGRAM

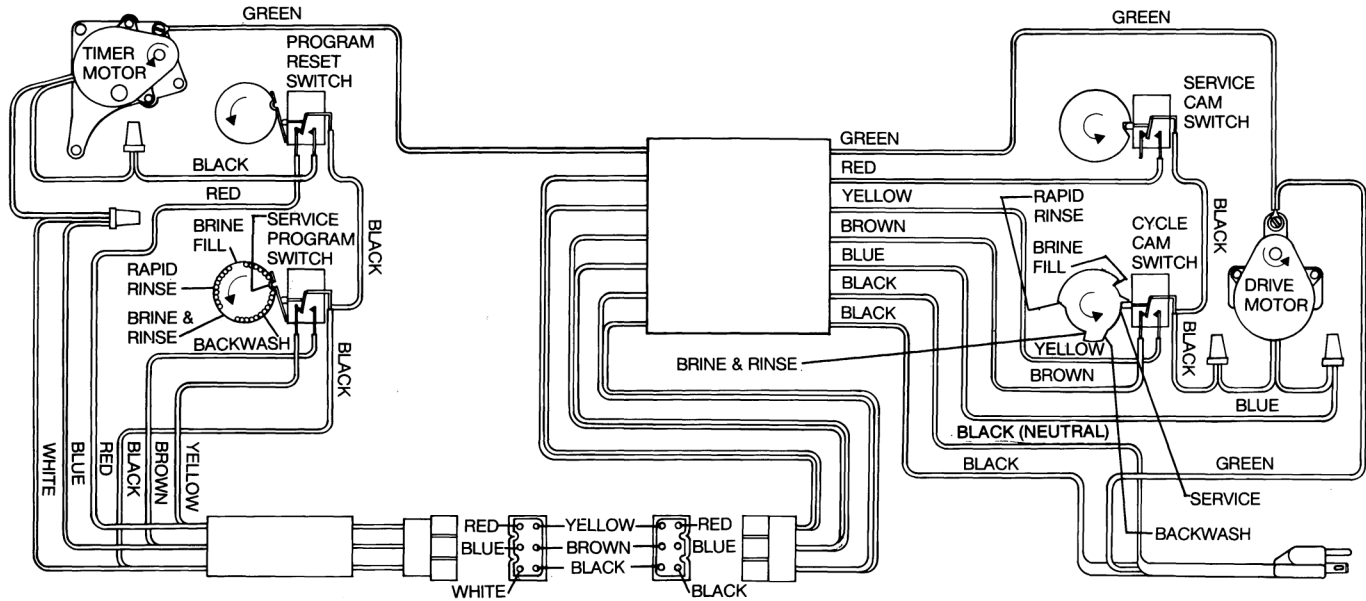

CONTROL INFORMATION

Tank Size Dia.	Injector	Slow Rinse Rate (gpm)	B.L.F.C. ¹	D.L.F.C. ²	Timer Motor	Timer Setting ³
6"	#0 Red	.26 gpm	.5 gpm	1.2 gpm	1/15 rpm	8-54-6-6
7"	#0 Red	.26 gpm	.5 gpm	1.2 gpm	1/15 rpm	8-54-6-6
8"	#1 White	.33 gpm	.5 gpm	1.5 gpm	1/15 rpm	8-54-6-6
9"	#1 White	.33 gpm	.5 gpm	2.0 gpm	1/15 rpm	8-54-6-6
10"	#1 White	.33 gpm	.5 gpm	2.4 gpm	1/15 rpm	8-54-6-6
12"	#2 Blue	.64 gpm	1.0 gpm	3.5 gpm	1/15 rpm	8-54-6-6
13"	#2 Blue	.64 gpm	1.0 gpm	4.0 gpm	1/30 rpm	8-60-6-6
14"	#3 Yellow	.89 gpm	1.0 gpm	5.0 gpm	1/30 rpm	8-60-6-6
16"	#3 Yellow	.89 gpm	1.0 gpm	7.0 gpm	1/30 rpm	8-70-6-6

¹ B.L.F.C. (Brine Line Flow Control). Refill Rate for Filling Brine Tank.

² D.L.F.C. (Drain Line Flow Control). Backwash and Rapid Rinse Flow Rates.

³ 8-54-6-6 Refer to -8 min. Backwash; 54 min. Brine and Slow Rinse; 6 min. Rapid Rinse; 6 min. Brine Tank Refill.

Note: Due to varying water conditions, tank sizes and water pressures, the above settings should be used only as a guideline.

MODEL 9000 ECONOMINDER®

Controlled Dimensions

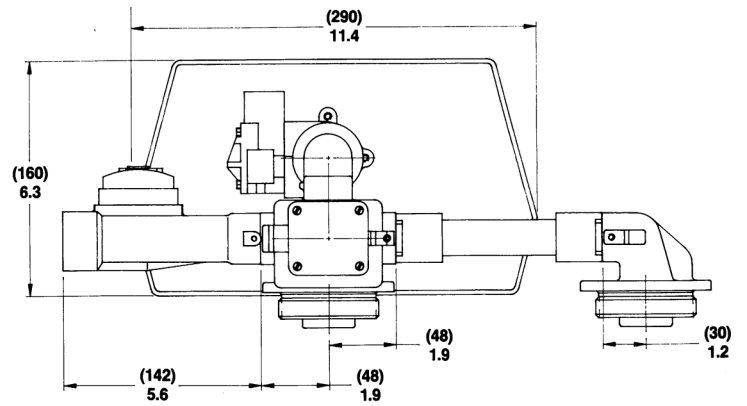
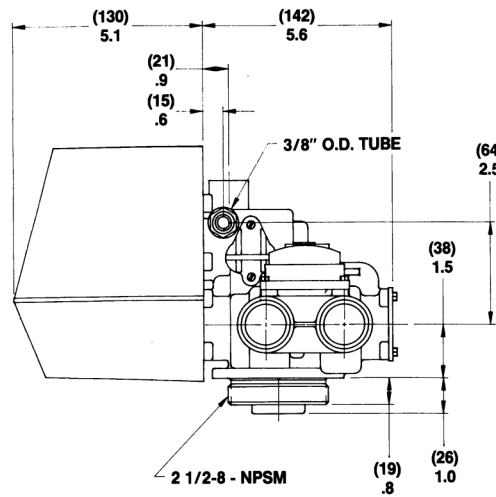
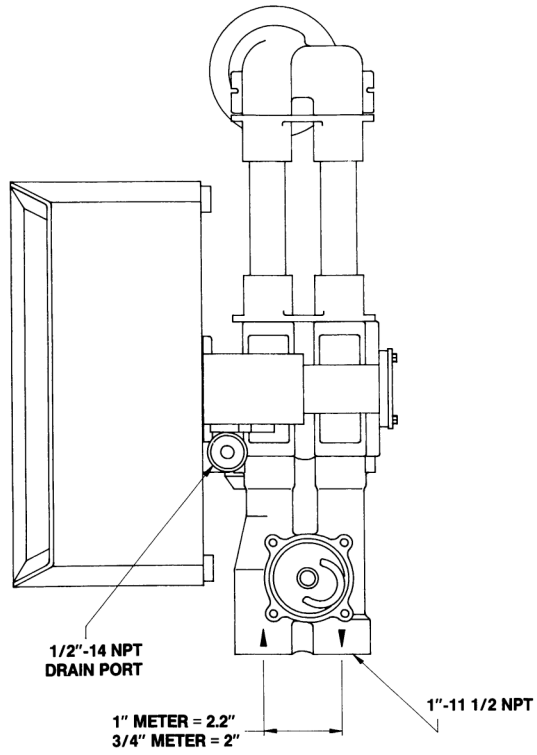

MODEL 9000 ECONOMINDER®

Service Assemblies

60022-25 BLFC .25 GPM	60400 Piston Assy, 9000 Upper
60022-50 BLFC .50 GPM	For Illustration, See Page 14
60022-100 BLFC 1.0 GPM	1 11335 Screw, Fil Hd
For Illustration, See Page 14	Mach 4-40 X 3/16
1 12094 Flow Washer .25 GPM	1 13446 End Plug, White Assy
12095 Flow Washer .50 GPM	1 14309 Retainer, Piston Rod
12097 Flow Washer 1.0 GPM	1 14914 Piston, Upper 9000
1 12977 O-Ring - 015	1 14919 Piston Rod, Upper
1 13244 Adapter, BLFC	1 14921 Link, Piston Rod
1 13245 Retainer, BLFC Button	
	60125 Seal & Spacer Kit,
60350 Brine Valve Assy, 9000	9000 - Upper
For Illustration, See Page 14	For Illustration, See Page 14
1 11973 Spring, Brine Valve	5 13242 Seal
1 11981 Retaining Ring	4 14241 Spacer
1 16095 Washer, Plain #10 Nylon	
1 12550 Quad Ring, -009	60421 Seal & Spacer Kit, 9000 -
1 12626 Seat, Brine Valve	Lower
1 13165 Cap, Brine Valve	For Illustration, See Page 14
1 13167 Spacer, Brine Valve	11 13242 Seal
2 13302 O-Ring, -014	8 14241 Spacer
1 14925 Brine Valve Stem, 9000	1 16595 Spacer, 9000
60385-XXXX Injector/Drain Assy	60412 9000 Powerhead Assembly
See "Parts Price List"	See "Parts Price List"
60086 3/4" Meter, Standard Range	60375-XX 9000, Timer 1/15 RPM
60087 3/4" Meter, Extended Range	60376-XX 9000, Timer 1/30 RPM
For Illustration and Parts	See "Parts Price List"
See Page 19	
60389 1" Meter, Standard Range	60136-9000 9000 Service Repair Kit
60390 1" Meter, Extended Range	See "Parts Price List"
For Illustration and Parts	
See Page 18	DLFC, Flow Washers
60401 Piston Assy, 9000 Lower	12085 Flow Washer, 1.2 GPM
For Illustration and Parts	12086 Flow Washer, 1.5 GPM
See Page 14	12087 Flow Washer, 2.0 GPM
1 11335 Screw, Fil Hd	12088 Flow Washer, 2.4 GPM
Mach 4-40 x 3/16	12089 Flow Washer, 3.0 GPM
1 13446 End Plug Assy White	12090 Flow Washer, 3.5 GPM
1 14309 Retainer, Piston Rod	12091 Flow Washer, 4.0 GPM
1 14905 Piston, Lower 9000	12092 Flow Washer, 5.0 GPM
1 14920 Piston Rod, Lower	12408 Flow Washer, 7.0 GPM
1 15019 Link, Piston Rod	

MODEL 9000 ECONOMINDER®

Service Assemblies, Hot Water

60612.....1" Meter, Standard Range, HW

60632.....1" Meter, Ext. Range

60401-01Piston Assy, 9000 Lower, HW

For Illustration and Parts List

See Page 14

- 1.....11335.....Screw, Fil Hd Mach 4-40 x 3/16
- 1.....13446-01End Plug Assy White
- 1.....16590.....Retainer, Piston Rod, HW
- 1.....14905.....Piston, Lower 9000
- 1.....14920.....Piston Rod, Lower
- 1.....15019.....Link, Piston Rod

60400-01Piston Assy, 9000 Upper, HW

For Illustration, See Page 14

- 1.....11335.....Screw, Fit Hd Mach 4-40 x 3/16
- 1.....13446-01End Plug, White Assy
- 1.....16590.....Retainer, Piston Rod
- 1.....14914.....Piston, Upper 9000
- 1.....14919.....Piston Rod, Upper
- 1.....14921.....Link, Piston Rod

60125 HWSeal & Spacer Kit, 9000 - Upper, HW

For Illustration, See Page 14

- 5.....18759.....Seal
- 4.....14241-01Spacer

60421 HWSeal & Spacer Kit, 9000 - Lower, HW

For Illustration, See Page 14

- 11.....18759.....Seal
- 8.....14241-01Spacer
- 1.....16595.....Spacer, 9000

Yoke Assy.

- 15823-066" Tank & 6" Tube
- 15823-088" Tank & 4.26" Tube
- 15823-126"-12" Tank & 8-1/2" Tube
- 15823-1414" Tank & 10-1/2" Tube
- 15823-1616" Tank & 12-1/2" Tube

